



Installation Manual

Cirrus Outdoor Display System

Revolutionary, ultra-high resolution digital displays

V04 2022

CIRRUS ON-PREMISE MARKETING

Contact

Tel (877) 636-2331

Email support@cirrusled.com | sales@cirrusled.com

Web www.cirrusled.com

Cirrus HQ

200 West Rd.

Portsmouth, NH. 03801



Table of Contents

Introduction	3
Equipment description	3
Safety/compliance information	8
Environmental considerations	9
Shipping/receiving, product storage	9
Warranty terms for all displays	10
Frames and assembly	13
Frames with bolts assembly	13
Quick-lock frames assembly	14
Frame covers assembly	17
Frame mounting	19
Ventilation	20
Electrical details	22
Power cable	22
Power injectors	23
Controller	24
Controller details	24
Mounting the Controller	25
Extension cables	25
Connecting the all-in-one antenna	26
Mounting the all in-one-antenna	27
Controller indicator codes	28
Automapping procedure.....	29
Panels	30
Connecting panels	31
Cable connections	32
Wiring pattern	33
Network connections	34
Important network information (Ethernet or WiFi kit only).....	35
WiFi kit installation	36
Connecting the WiFi kit	37
Getting started: Digital Window Poster	38
Digital Window Poster installation manual.....	38

Introduction

Equipment description

Cirrus Outdoor Display Systems are modular signs consisting of these components:

Frame



Quick lock frame



Standard frame



Frame bolts, 1/4"-20x0.5"

Cirrus Outdoor LED sign module

Cirrus Outdoor

BladeM

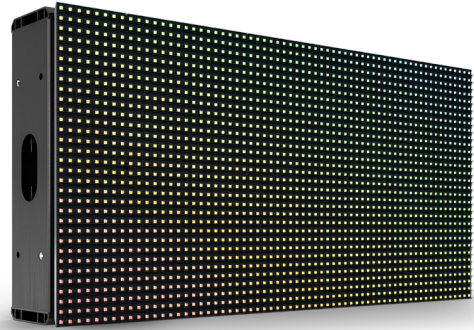
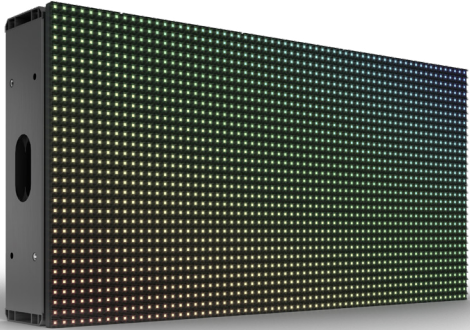

Front view

Front view

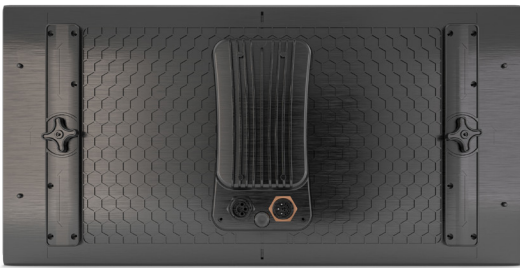

Rear view

Rear view



Panel to panel cable

Panel to panel cable

Controller

To manage single and dual-sided signs

Cirrus Outdoor



Controller

BladeM



Controller



Controller to panel cable



10' Extension cable (x2)



Power cable



Power cable

All-in-one antenna



All-in-one antenna



Antenna side mounting bracket

Wireless access kit

Optional, may not be included

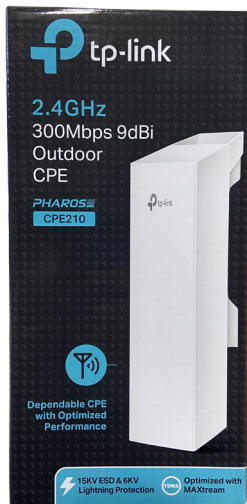

TP-Link wireless kit



10' Ethernet cable (x2)

Power injector

Optional, may not be included

Cirrus Outdoor



Smart power injector



Power cable



Panel to panel cable

BladeM



Power Injector



Power cable



Panel to panel cable

Safety/compliance information

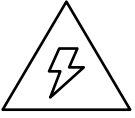

High voltage

Contact with high voltage from AC mains may cause death or serious injury. Always disconnect AC power to unit prior to servicing.



Grounding

It is essential to earth-ground the sign before connecting controller. Connecting signs that are not earth grounded may cause damage to the LED Display System and in severe cases cause death or injury.

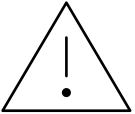

Other

Other safety messages appear throughout this manual where appropriate.

Cirrus LED components are UL Listed. File #E352796 and FCC Certified.

FCC information

This equipment has been tested and found to comply with the limits for a Class A digital device, pursuant to part 15 of the FCC Rules. These limits are designed to provide reasonable protection against harmful interference when the equipment is operated in a commercial environment. This equipment generates, uses, and can radiate radio frequency energy and, if not installed and used in accordance with the instruction manual, may cause harmful interference to radio communications. Operation of this equipment in a residential area is likely to cause harmful interference in which case the user will be required to correct the interference at his own expense.

Changes or modifications to this device that are not expressly approved by Cirrus Systems, Inc. could void user's authority to operate this device.

Environmental considerations

The Cirrus Outdoor LED panels are fully encapsulated and water-proof. The Controller is housed in a water-proofed aluminum enclosure.

The Cirrus Outdoor LED panels are rated for an ambient operating temperature range of -40~+70° Celsius (-40 ~ +158° Fahrenheit) and are designed to withstand continuous direct sunlight. If the panels experience an over-temperature condition, a signal will be sent to the controller to shut down the sign. Once the sign has cooled, it will automatically restart.

The Controller is rated for an ambient operating temperature range of -10~+60°C (14~ +140°F) and should be protected from direct sunlight. Operation at colder temperatures is routinely and regularly accomplished, though starting the screen from a powered off state at temperatures below 14°F may not be possible. A controller which is in a powered on state produces ambient heat which can allow it to continuously run at temperatures as low as -30°F (-34°C).

All components and connections are sealed and water-tight for protection from the ingress of dust and water, though no components should be subjected to immersion in water.

Shipping & Receiving, product storage

All deliveries shall be FOB Cirrus Systems (Seller), Portsmouth, NH. Methods and routes of shipment, unless Seller specifies in writing otherwise, shall be accepted as chosen by Seller at Seller's sole discretion. Purchaser shall pay all costs of shipment. Delivery to the carrier shall constitute delivery and passage of title to Purchaser, and risk of loss shall pass to Purchaser concurrently with passage of title. Seller will use reasonable diligence to meet scheduled shipment dates and times. Such dates and times are the best possible estimates, and not guarantees, of when goods will be shipped. In no event shall Seller be liable for any losses or damages of any kind due to delays in shipment, nor may Purchaser cancel its contract because of any such delay.

It is the responsibility of the Purchaser to check the Product for visible damage prior to accepting delivery from the carrier. Any damage to the Product must be noted on the delivery slip with the carrier and immediately reported to Cirrus. Photographic evidence of damages will be required. Cirrus may assist in seeking remedy with the carrier for damaged goods but does not retain title and therefore is not legally responsible for said damages.

Delivered product should be stored in a cool dry place, out of the way of foot/motorized traffic.

It is the installer's responsibility to look over the product before installing to ensure there are no missing parts and there is no visible damage to any parts of the display. If there is any damage, Cirrus must be informed prior to install.

Warranty terms for all displays

What this warranty covers

This warranty covers any defects, failures, or malfunctions of any Cirrus LED display system hardware.

All inspections of warranted components will be conducted within 72 hours and results will be presented immediately thereafter and applicable charges will be sustained or reimbursed at that time.

12mm pixel warranty (per panel) - 1st year, 100% pixel guarantee, 2 pixels for years 2-3 and then 3 pixels for years 4-5

9mm pixel warranty (per panel) - 1st year, 100% pixel guarantee, 2 pixels for years 2-3 and then 3 pixels for years 4-5

6mm pixel warranty (per panel) - 1st year, 100% pixel guarantee, 4 pixels for years 2-3 and then 6 pixels for years 4-5

4mm pixel warranty (per panel) - 1st year, 100% pixel guarantee, 8 pixels for years 2-3 and then 12 pixels for years 4-5

Coverage period

This warranty lasts for five calendar years following the purchase of any Cirrus LED display system. Warranty may not be exercised until the display has been installed, powered, connected to the Internet and Cirrus has verified adequate setup. Displays that are stored for extended periods of time and not installed within 90 days of shipment may not qualify for warranty coverage at the discretion of Cirrus Systems Inc. Coverage terminates if an end user sells, transfers, opens or tampers with any display system or its internal components.

What's covered

Cirrus will replace any defective or malfunctioning part at no charge and pay for shipping. All defective parts must be returned to Cirrus Systems for servicing upon failure. Replacement components will be dispatched once a credit card has been secured to guarantee the return of the defective part. Replaced parts are required to be returned within 21 days of shipment or a charge for the cost of the replacement part will be applied to the held credit card.

What's not covered

This warranty does not cover labor costs or any problem that is caused by abuse, misuse, improper installation, or an act of God. Also, consequential and incidental damages are not recoverable under this warranty. Some states do not allow the exclusion or limitation of incidental or consequential damages, so the above limitation or exclusion may not apply to you. Cirrus will not be responsible for any labor charges incurred during assembly, disassembly, or any other services related to the part replacement.

Service eligibility

Any company or individual that purchases a display from Cirrus Systems or from an authorized Cirrus distributor is eligible for this warranty and service. If issues are experienced with any display system, contact Cirrus at (877) 636-2331 and follow the prompts for technical support.

Exclusions

The following issues are not covered under the limited warranties set forth above. For these issues, Cirrus shall not be obligated to furnish warranty support or maintenance services, nor shall Cirrus be liable hereunder for repairs, replacement or additions:

- 01.** Damage or problems caused during transportation by Customer;
- 02.** Defects or damage that result from use of the Products or Software in other than their normal and customary manner;
- 03.** Damage or problems caused by repairs, changes, modifications, maintenance, relocation or reinstallation by other than Cirrus designated technicians, or without Cirrus's written permission;
- 04.** Products and Software subject to unauthorized modification, disassembly or repair (including the addition to the Product of non-Cirrus authorized and supplied equipment) which adversely affect Product or Software performance or interfere with Cirrus's normal warranty inspection and Product or Software testing for warranty verification;
- 05.** Products which, due to illegal or unauthorized alteration of Product software or firmware, do not function in accordance with Cirrus's published specifications;
- 06.** Damage or problems caused by not following Electro-Static Discharge ("ESD") precautions when handling Covered Products;
- 07.** Damage or problems caused by improper electrical grounding;
- 08.** Damage or problems caused by improper utility service;
- 09.** Damage or problems caused by use of non-Cirrus supplied equipment or parts;
- 10.** Damage or problems caused by misuse, abuse, neglect or accident;
- 11.** Damage or problems caused by an external electrical fault or any unusual shock;
- 12.** Damage or problems caused by an accident, fire or water;
- 13.** Damage or problems caused by natural disasters such as flood, fire, lightning, earthquake or tornado.
- 14.** Damage or problems caused by failure to maintain the proper operating or storage environment for the Covered Products to include but not limited to air conditioning, humidity control, or corrosive atmosphere harmful to electronic equipment as provided in the Cirrus Installation Manual;
- 15.** Damage or problems caused by strikes, riots, sabotage, or acts of war;
- 16.** Theft;
- 17.** Routine cleaning, or normal and customary wear and tear;
- 18.** Scratches or other cosmetic damage to Product surfaces that do not affect the operation of the Product;
- 19.** Technical support or maintenance of any kind for third-party application or custom software not defined under Covered Products;
- 20.** Technical support associated with programming of Application Program Interfaces (API) of Covered Products except for support on the capabilities of the programming interface;
- 21.** Consumables and supplies (i.e., expendable batteries, recording media, tapes, disks or other consumables);
- 22.** Freight costs to the repair depot;
- 23.** Non-Cirrus manufactured equipment, which carries its original manufacturer's warranty and which will be provided to Customer upon request.
- 24.** Components damaged due to arcing or connecting/disconnecting while powered on.
- 25.** Components damaged due to excessive heat buildup (in the case of improperly vented displays).

Warranty activation

The 5 year product warranty will go into effect upon the date of shipment and transfer of title. Warranty may not be exercised until the display has been installed, powered, connected to the Internet and Cirrus has been called to verify the installation. Displays which are stored for extended periods of time and not installed within 90 days of shipment may not qualify for warranty coverage at the discretion of Cirrus Systems Inc.

TP-Link Wifi kit warranty

Cirrus will cover the first year of warranty of the TP-Link WiFi kit and its power supply. After the first year of use, client must work through the warranty with TP-Link directly.

Disclaimer

Except as expressly set forth in this Agreement, the Products and Software, including the Hardware, and all related Services shall be provided “as is” without warranty of any kind, and Cirrus hereby disclaims, and Customer hereby waives, any and all warranties whether express, implied or statutory, including all implied warranties of merchantability, fitness for a particular purpose and non-infringement. Further, Cirrus does not warrant, guarantee, or make any representations that any Software provided will be free from all bugs or that its use will be uninterrupted or error-free. Customer understands and agrees that Cirrus is not responsible for and will have no liability for equipment hardware, software, or other items or any services provided by or manufactured by any persons other than Cirrus or its authorized agents. The foregoing constitutes Customer’s sole rights and remedies under this agreement with respect to defects in the products, software or services.

Limitation on liability

Buyer understands and agrees that except for instances involving Cirrus’s indemnification obligations set forth in the governing Sales Agreement, Cirrus’s aggregate liability for any damages suffered by Buyer or any other party, whether in contract, in tort, under any warranty theory, or otherwise, shall be limited to the amount paid to Cirrus by Buyer under this Contract for the defective System component(s) giving rise to the indemnified losses or damages covered by this Agreement.

Frames with bolts assembly



1' tall x 2' wide frames are assembled using the included 1/4" hex bolts. It is important to ensure that all frames are attached with the arrows facing front and up.

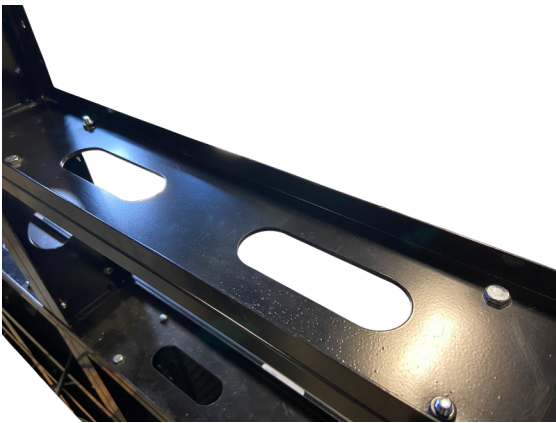
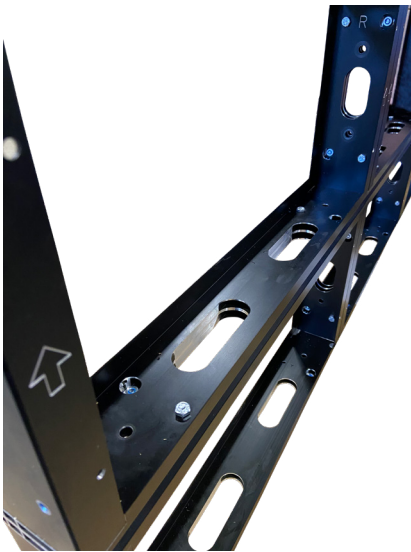

Four bolts should be used on each side of the frame and should be tightly fastened to ensure there are no gaps between the panels. Two bolts will go in from one direction and two will go in from the opposite direction, on each side.

Quick-lock frames assembly

Step 01. Align frames

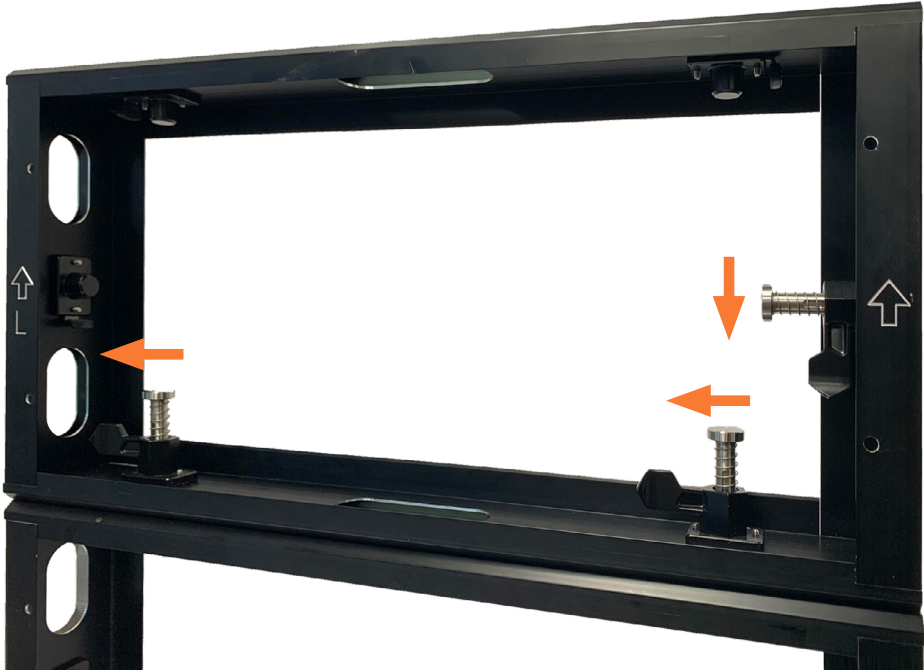

Quick-lock frames assembly (continued)

Step 02. Press down on plunger until you hear a click and feel the locking mechanism snapping into place

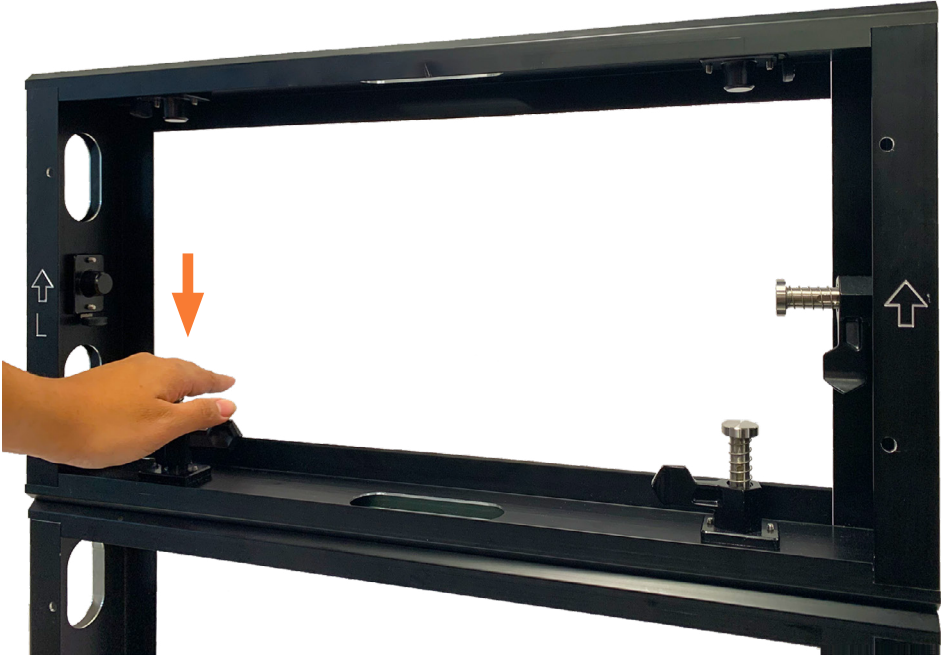

Step 03. Twist locking handle counterclockwise until secure



Quick-lock frames disassembly

Step 01. Turn locking handle clockwise

Step 02. Pinch lock release button together until you see the plunger release



Frame covers assembly

What's inside the box

	Item description	Item quantity
Frame covers and snaps	(8) Frame cover snaps for every (1) 2 ft. Horizontal Frame Cover	Varies
	(4) Frame cover snaps for every (1) 1 ft. Vertical Frame Cover	Varies

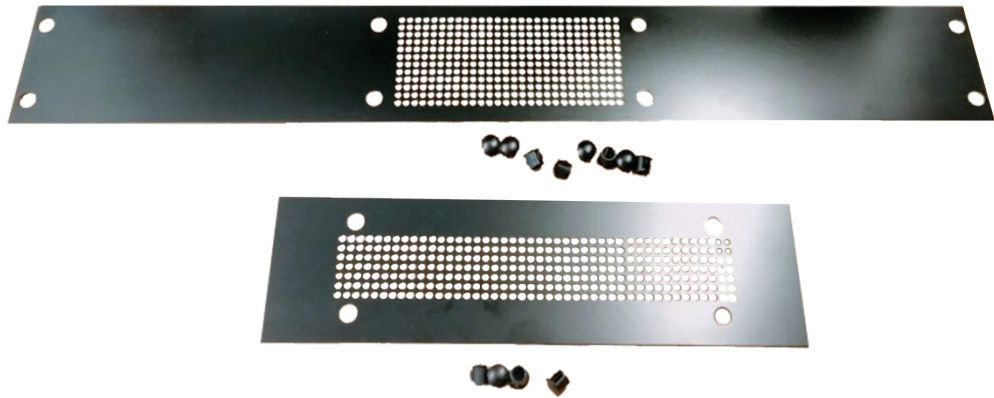

Frame covers assembly (continued)

Step 01. Align frame cover with perimeter frame

Step 02. Press frame cover snaps provided into the provided holes

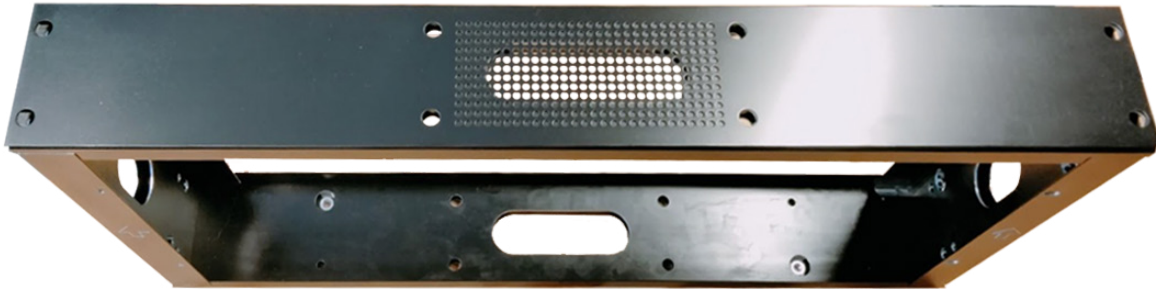

Frame mounting

Cirrus LED signs should never be transported with the panels already in place - any damage that is incurred due to transport will not be covered under warranty. This includes damage to edge diodes, damage from strapping or lifting signs into place for mounting/ installation purposes.

One row of support mounting brackets(not supplied) must be attached for every four rows of frames. Do not exceed four rows of frames without attaching an additional mounting bracket.



Mounting brackets should be attached for the entire horizontal length of the frames to prevent bowing or lateral stress.

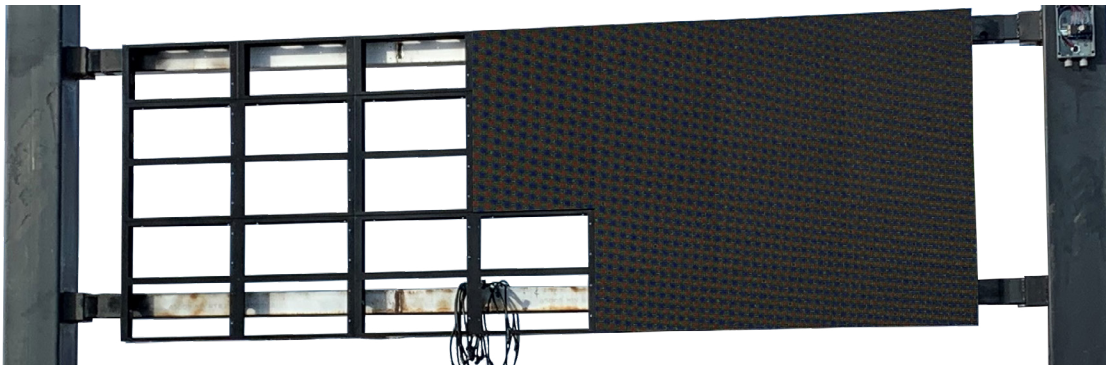

Ventilation

Cirrus LED panels are passively cooled, so ventilation is required to keep the display within normal operating temperatures (-40 ~+70 C or -40 ~+158 F ambient temperature). Allowing natural convection by venting the top and bottom of the display is required. Damage from overheating is not covered under warranty.

PLEASE NOTE:

The following guidelines are our standards, but may not be adequate in all locations or installations. Additional ventilation or changes may be required based on site conditions.

Allow minimum of 2" gap per face behind the sign for air flow.

- **DO NOT RESTRICT AIRFLOW** around the backs of the panels.
- When using mesh, louvers or other covering: Use actual open area of the louver, not the cutout size, for calculation.*

Total air intake (bottom of sign) = 12-18 square inches per foot of sign

Total air exhaust (top of sign) = 12-18 square inches per foot of sign

- Never mount an ID sign or sign cover without satisfying the guidelines illustrated above. These ventilation requirements apply for signs of all types and all sizes.
- **DO NOT OBSTRUCT AIR INTAKE** in the bottom front of the sign.
- Do not cover the front of the sign with glass or polycarbonate, or obstruct air flow in any way.
- Allow 14" clearance below sign for water drainage.

* Smaller openings in mesh/louvers will require a larger section to achieve the same ventilation.

Static Cabinet Integration

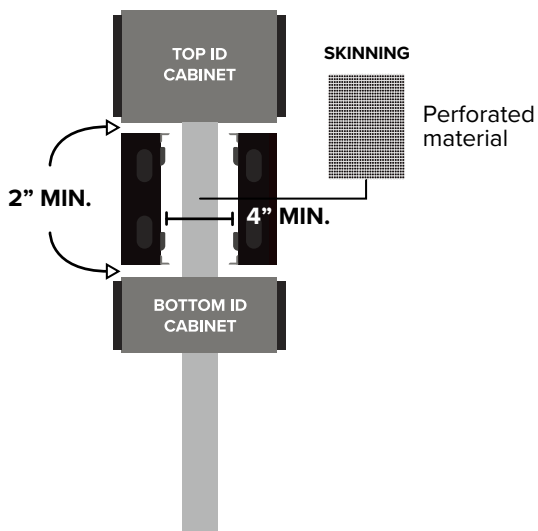

2" MIN. of space on top and bottom of the display are required for warranty. To increase convection, the sides of the display can be left open or covered with a perforated material.

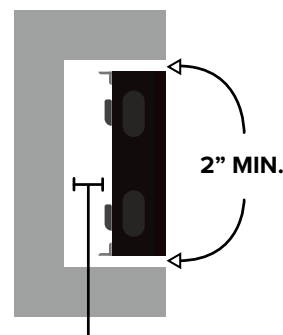
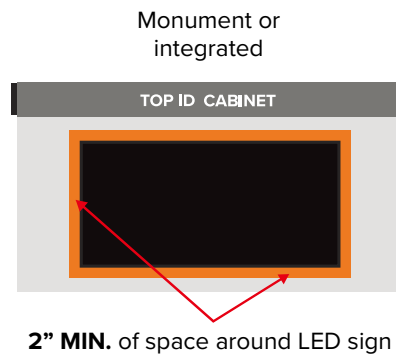

4" MIN. when recessed

Single face wall mount

Ventilation (continued)

2" MIN. space required on top and bottom for convection

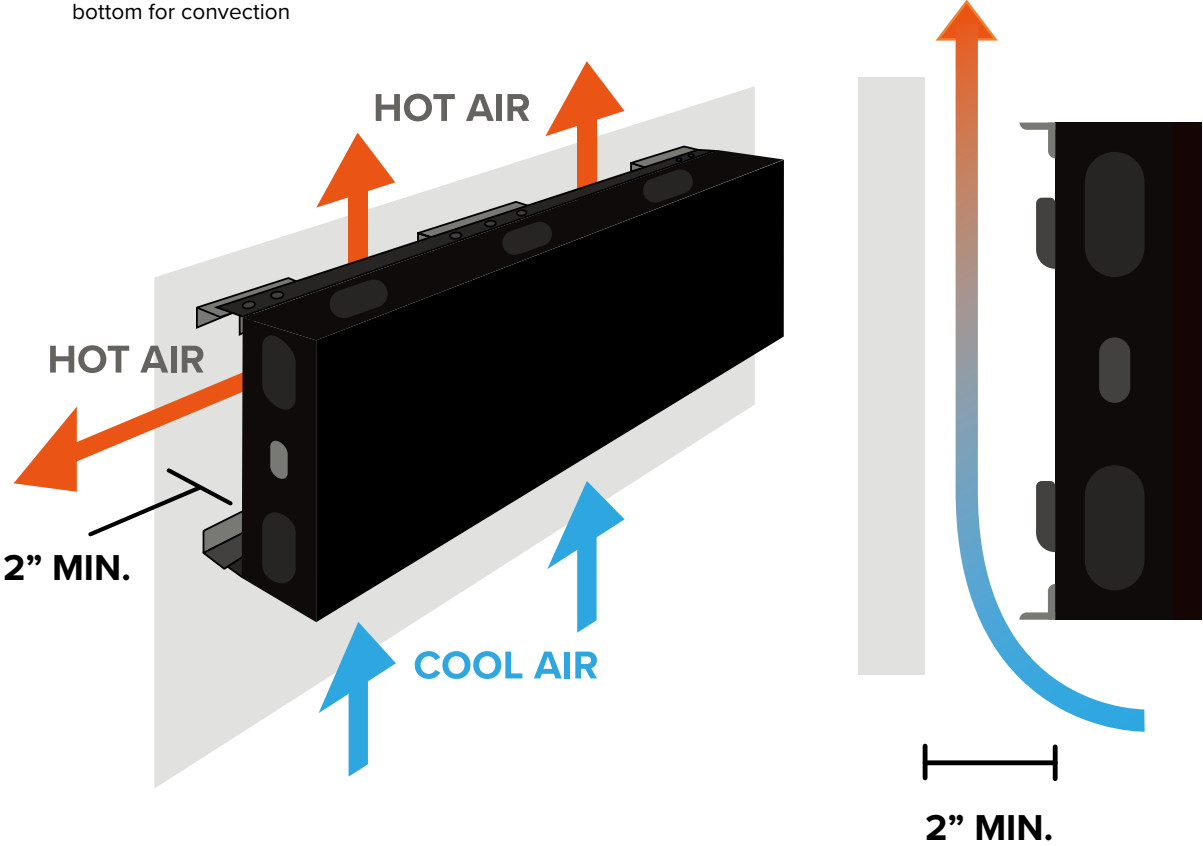

2" MIN. space to allow for proper convection, required for warranty

Electrical details

IMPORTANT: Connecting or disconnecting components should NEVER be done when power is live. Always turn off the breaker prior to unplugging or connecting cables, panels, controllers, or power boosters. All electrical breakers should be no more than 20 amps. The circuit should **ONLY** be connected to Cirrus equipment and can not be shared with any other equipment (other LED drivers, cabinet lighting, etc). It should also not have any sort of timer on them. **Ground Fault Indicator (GFI) breakers should never be used.**

The Cirrus outdoor display system is designed to be powered by 120 to 240-volt single-phase service, without any additional configuration or equipment. The exact electrical requirements will be determined by the number of panels. **Cirrus is unable to provide, consult, or advise on the electrical setup for the display. All electrical work must be done by a licensed electrician in accordance with local laws and regulations.**



IMPORTANT - Improper electrical setup, unstable or inconsistent power, “dirty power”, harmonic feedback and other abnormal electrical conditions may damage or destroy display hardware and are not the responsibility of Cirrus, nor will part repair or replacement due to such damage be covered under the Cirrus warranty. The use of a generator to power a display is **NOT RECOMMENDED**, and may result in damage to the display, which would not be covered under warranty. With the introduction of the Controller, there is now a built-in power detection system. If power issues are detected (such as insufficient power for the number of panels), the panels will be shut off automatically as a safety measure. A rapidly flashing red light on the Controller will indicate a power issue. Cirrus Tech Support should be contacted before restoring power to the panels. **Electrical damage MAY have already occurred and does not change the warranty coverage.**

	Outdoor 12mm	Outdoor 9mm	Outdoor 6mm	BladeM 9mm	BladeM 6mm
120 Volt	28	22	22	18	16
208 Volt	45	37	39	32	28
240 Volt	49	43	43	36	32

For signs requiring more than one circuit of power, a power injector(s) will be used to provide additional power. Refer to the power injector section for more details.

Power cable



-  **Green** — Ground
-  **Black** — Hot
-  **White** — Neutral (120-volt service) or hot (240-volt service)

Note: Displays must be properly grounded (at the breaker or at the display). Electrical damage is not covered under our warranty (refer to the warranty section for details). A sign bonded to an earth ground has a means of dissipating the high voltage and current from a lightning strike. The resistance of the grounding electrode must be as low as possible. However, damage can still occur to a sign’s electronic equipment from lightning voltage transients. The earth ground must comply with NEC Article 250. Though some surge protection is incorporated into a sign, to protect a sign from high-voltage lightning transients, surge protectors can be installed in accordance with NEC Articles 280 and 285 and local codes. The Cirrus warranty cannot cover damaged caused by lightning transients.

Power injectors

Power injectors are used in cases where a sign requires more than a single line of power. Cirrus will advise on where to place power injectors as part of the pre-install process.

Cirrus Outdoor

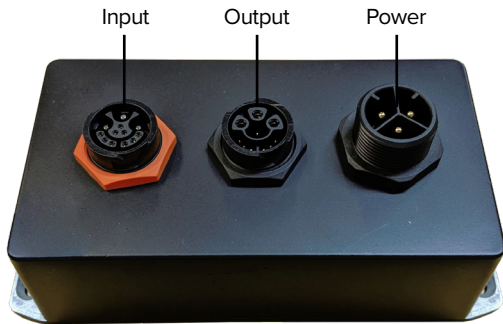

Smart power injector

BladeM

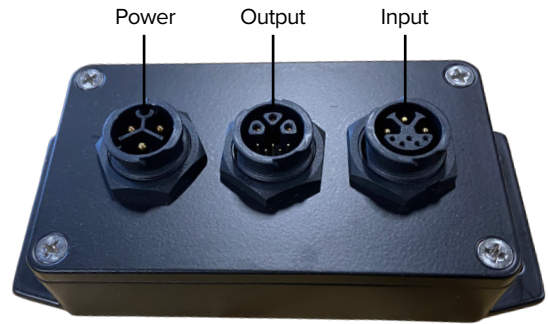

Power Injector

The power injector has three ports - one for the power cable, a cable input, and a cable output.

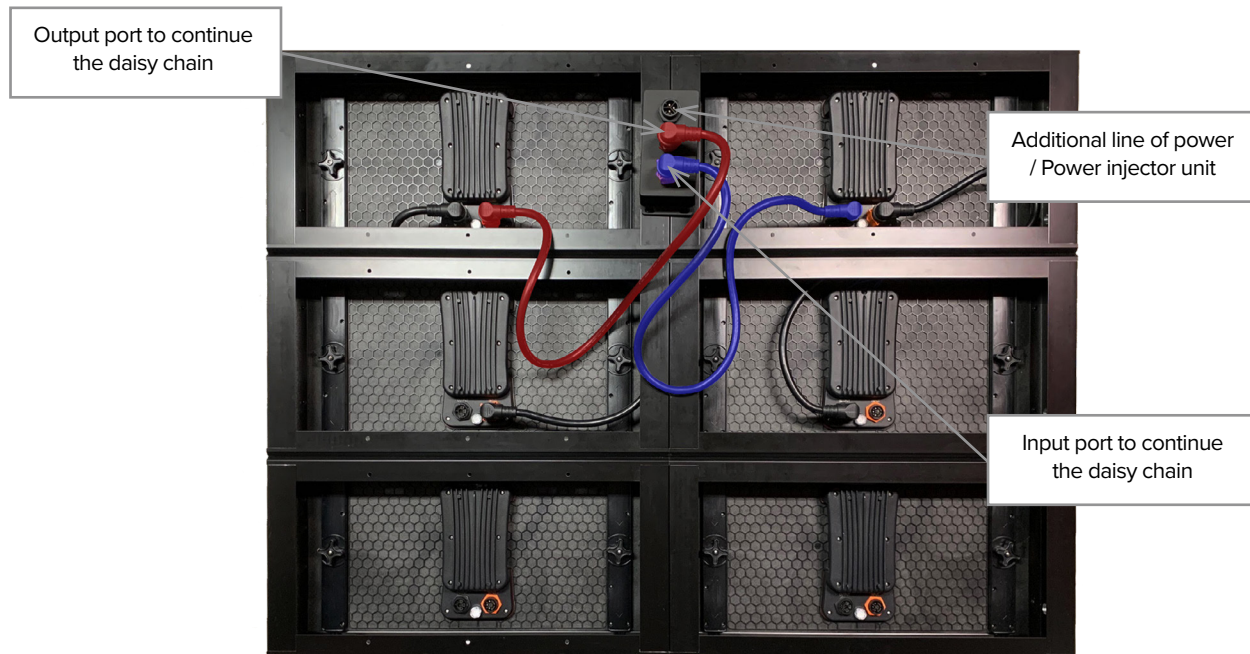

Controller

Controller details

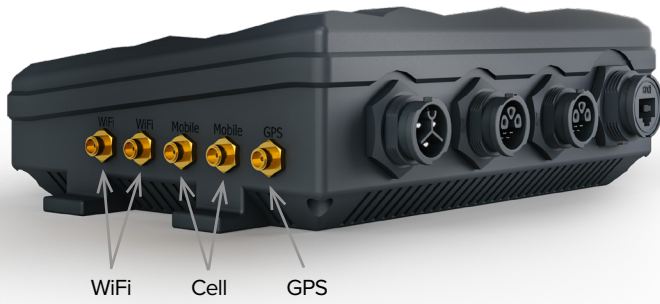
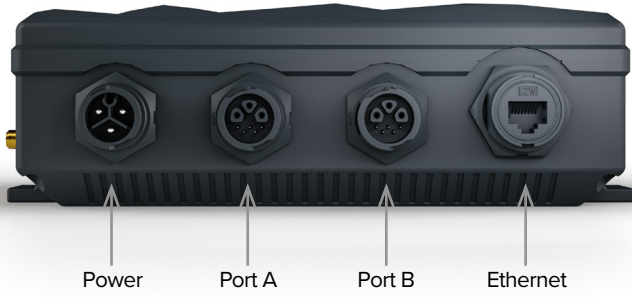

Mounting the controller

The Controller is recommended to be mounted inside the sign, to prevent unwanted access. It can be placed outside, but should not be mounted in direct sunlight.

The Controller should be mounted with the side with no ports facing up, so no water can pool in them. Pooling water may eventually cause damage to the interior components. The controller can be mounted horizontally as well.



Extension cables (only for BladeM)*

The included extension cables can be used to enable mounting the controller further away from the first panel in the chain. When using an extension, a 2' panel cable must be used to connect to a panel.

Note: Do not use two extension cables connected together, it may result in data loss and display issues.

*For Outdoor displays we include a 10ft controller to panel cable. It can only connect to a controller and a cable (it is not an extension cable).



Connecting the all-in-one antenna

The all-in-one antenna has 5 leads, 2 for wifi (unlabeled), 2 for cellular (purple, labeled LTE), and a GPS lead (blue).

The two wifi leads should be secured to the WiFi posts, the LTE leads should be secured to the mobile connections, and the GPS lead should be secured to the GPS connector.

It is critical to ensure all connections are securely tightened, as failure to do so may result in poor connectivity.

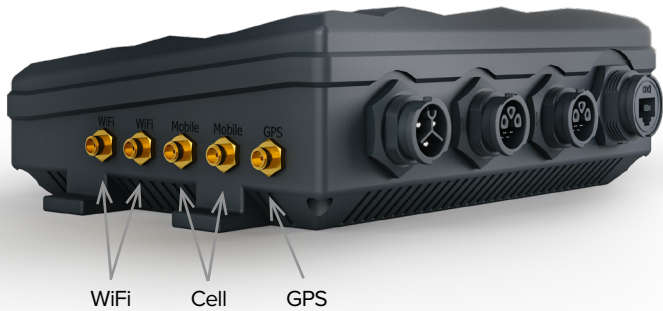

Mounting the all-in-one antenna

The all-in-one is designed to be mounted directly on the top of the sign. If the antenna is placed on the side or underneath, there will be a severe degradation of connectivity.

The cables can be fed through one of the openings on the frame, and then the locking nut secured down to hold it in place. The rear of the antenna also has 3M peel and stick tape which can be used to adhere to the in place of the locking nut.











Both mounting positions are acceptable to provide optimal reception*

Side mounting is not acceptable and will result in connection issues.

* bracket for side mounting is not supplied by Cirrus





Controller indicator codes

Indicator State	Meaning	Action
Steady green light 	Power on	n/a
Green light flashes every 5 seconds 	Power on, system monitoring active	n/a
Steady red light 	Power to modules is disabled	To restore power - hold button down for 2 seconds. Release when light turns green
3 green flashes, followed by a pause, for 10 seconds 	Network connection is active	Initiate network test - Press button once quickly
3 red flashes, followed by a pause, for 10 seconds 	Network connection is NOT active	Initiate network test - Press button once quickly
Steady blue light 	Automapping complete, test patterns will show for 2 minutes or until canceled	To initiate Automap - press and hold button for 5 seconds. To exit mode early - press button once quickly
Flashing red for 10 seconds 	Automapping failed	n/a
Flashing red every 0.5 seconds 	Power issue detected. Panels shut down	Contact Cirrus Support
Flashing green every 0.5 seconds 	Power issue overridden	Contact Cirrus Support

Automapping procedure

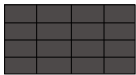
With our patented automapping technology, new signs can be installed without even making a phone call. After installing and connecting the Controller and all the panels. Following the instructions below will address all the panels and put the controller into a diagnostic mode, which will check the network connection before returning to normal function.

Automapping

- | | | |
|---------------|---|---|
| Step 1 |  | Install the panels and controller. Power up the display. |
| Step 2 |  | Hold the Button for 5 seconds and release when the light turns blue. |
| Step 3 |  | There is a pause while the controller attempts to send mapping data to the panels. |
| Step 4 |  | Once the automapping completes, a system check is initiated. The sign will show a rainbow pattern, then a network status. These will alternate for 2 minutes or until the Button is pressed once quickly. |

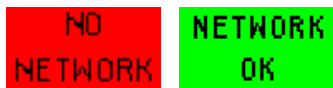

If the automapping process doesn't complete correctly, please reach out to **Cirrus Support at (877) 636-2331 option 2**



Green indicator



Red indicator



Blue indicator

Panels

Cirrus LED signs should never be transported with the panels already in place - any damage that is incurred due to transport will not be covered under warranty. This includes damage to edge diodes, damage from strapping or lifting signs into place for mounting/ installation purposes.

Cirrus panels are secured onto the framing system using 2 locking mechanisms. The panels should fit only one way, with the input and output port on the bottom of the panel. The locking arms are controlled by the knobs on either side of the panel.

Cirrus Outdoor

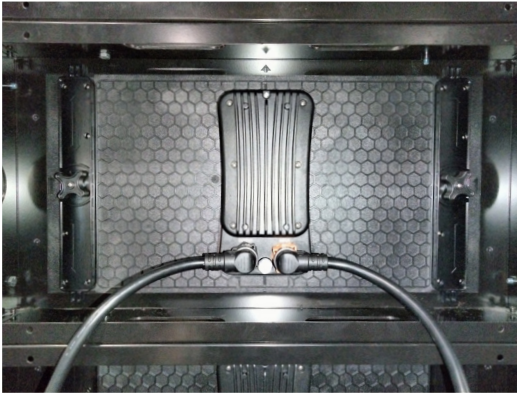

BladeM

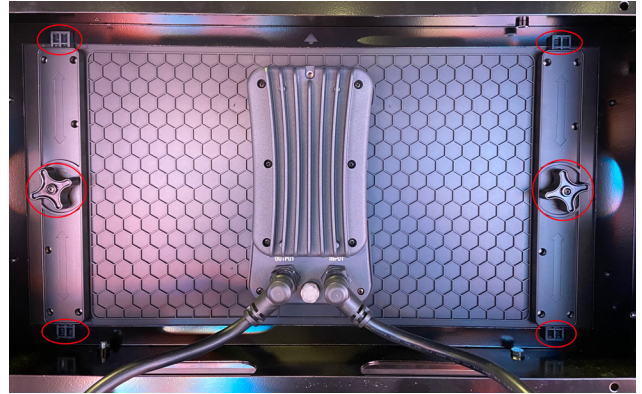

Front access:

The locking mechanism can also be accessed from the front of the display for service purposes using a 2.5 mm Allen wrench. There is a small hole opposite the knobs on the rear of the sign.

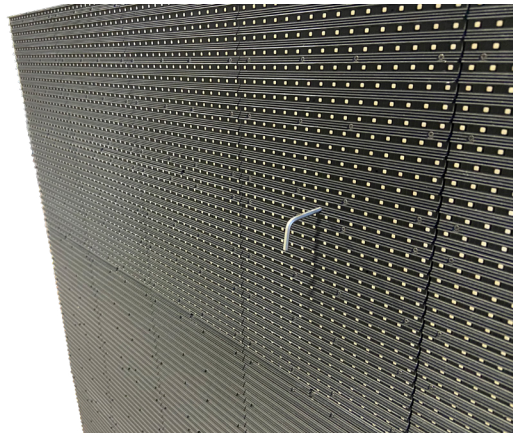

Connecting panels

IMPORTANT:

Connecting or disconnecting components should **NEVER** be done when power is live.
Always turn off the breaker prior to unplugging or connecting cables, panels, controllers, or power boosters.

Each panel will have an input cable and an output cable (except the last panel in the chain).
Each port should be labeled with the input on the right and the output on the left (when facing the back of the panel).

Cirrus Outdoor



BladeM



Cable connections



1. Align connector

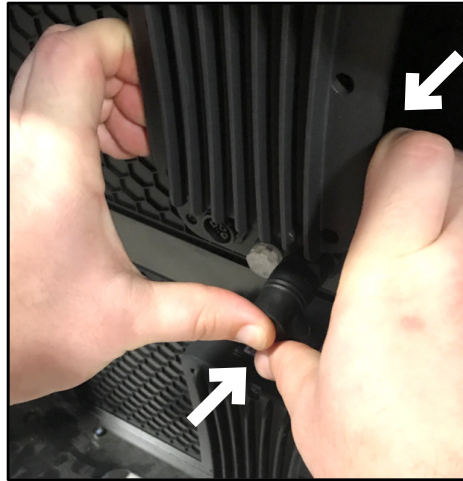

2. Grip heatsink with fingers to pull while pushing connector with thumbs. This push/pull method will avoid damaging the panel.



3. Use thumb to twist lock into place



4. Pull gently on cable to ensure lock is in place

Note: Using excess force when seating cables can lead to panel damage which will be present on display screen.

Wiring pattern

It is recommended to use the following daisy chain pattern when connecting modules together:

Port A

When facing the back of the sign start at bottom left corner then go up to the top left, then over one column, then down to the bottom, and so on.

3x6 wiring example – Port A

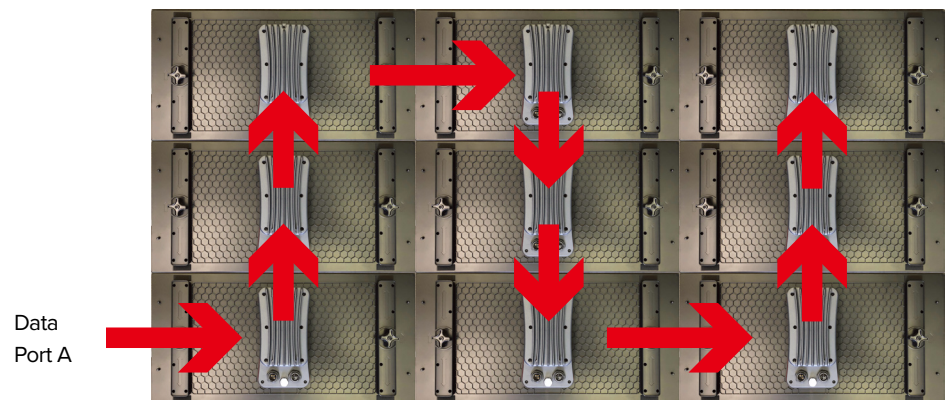

Port B

When facing the back of the sign start at bottom right corner then go up to the top right, then over one column, then down to the bottom, and so on.

3x6 wiring example – Port B

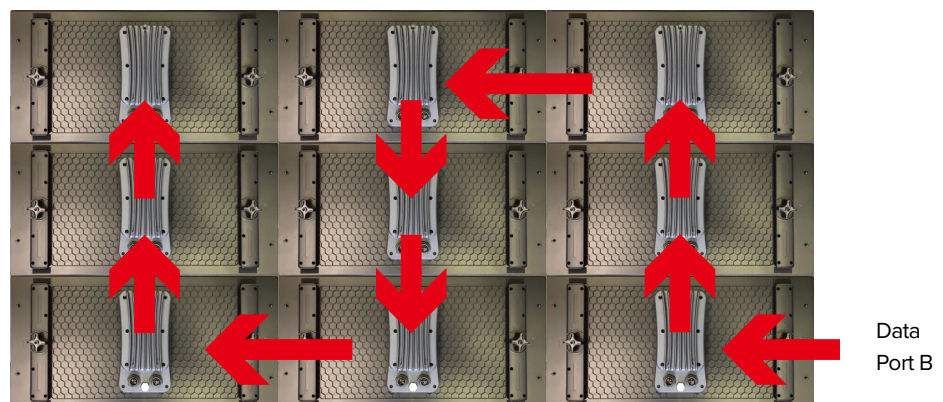

Network connections

An active network connection is required to use your Cirrus display. The display can be connected one of three ways:

Cellular broadband

Cellular broadband is optional on all Cirrus displays. Cellular coverage can vary from location to location, so may not always be the best solution. Your sales rep can give you more information.

Both the WiFi kit and the cellular broadband will require the installation of the all-in-one antenna.

Ethernet



A direct Ethernet connection can be plugged into the Ethernet port (labeled LAN) of the Controller pictured below.

Note: The maximum run on Ethernet is 300 ft, any distance greater than that can be run with fiber optic cable, but will need to be converted back to Ethernet before connecting to the controller.

WiFi kit (optional)

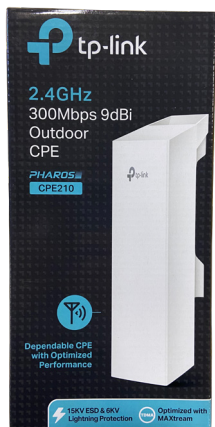

The included WiFi kit (pictured below) is preconfigured and is intended to be plugged into the location's network to broadcast a "CirrusLED" WiFi network, which our controllers connect to automatically. Installation instructions are on page 32.

Note: The maximum distance between the wifi kit and the sign is roughly 300' and maybe less depending on the line of sight. A second wifi kit can be added to make a paired set which more than doubles that distance. Contact your Cirrus Support for details and cost.

Important network information (Ethernet or WiFi kit only)

Both the Ethernet and WiFi kit have been preset to work with unrestricted access to the internet, through the customer's network. The default IP scheme is via DHCP.

In the case of a restricted network (firewalls, or static IP addresses), additional configuration can be performed. This is most easily performed before installation, so reach out to Tech Support.

WiFi kit installation (optional)

Inside the WiFi kit box are the following components:



Wireless access point
or WAP

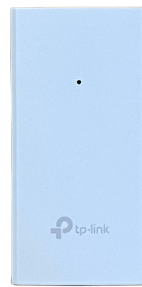

Power over Ethernet
or PoE



PoE power cable

Not pictured but required for installation are (2) Ethernet cables. We include (2) 10' Ethernet cables as part of the controller kit, but longer ones may be substituted if necessary. Cat5 or Cat6 are both acceptable.

The maximum run for standard Ethernet is 300'. Longer distances may be covered with fiber optic cable but must be converted back to standard Ethernet to connect to the controller.

Connecting the optional WiFi kit

The WAP is designed to be hung outside, with the flat front (has the logo printed on it) facing towards the sign. Line of sight is important to prevent signal loss, so putting it inside, pointing in a different direction, or through a screen of trees can all prevent good communication.

The PoE should be connected to a 120v outlet **no more than 30'** from the WAP. An Ethernet cable connects the PoE to the WAP, with one end plugged into the Ethernet port on the rear of the WAP, and the other on the PoE port of the PoE unit (see below).

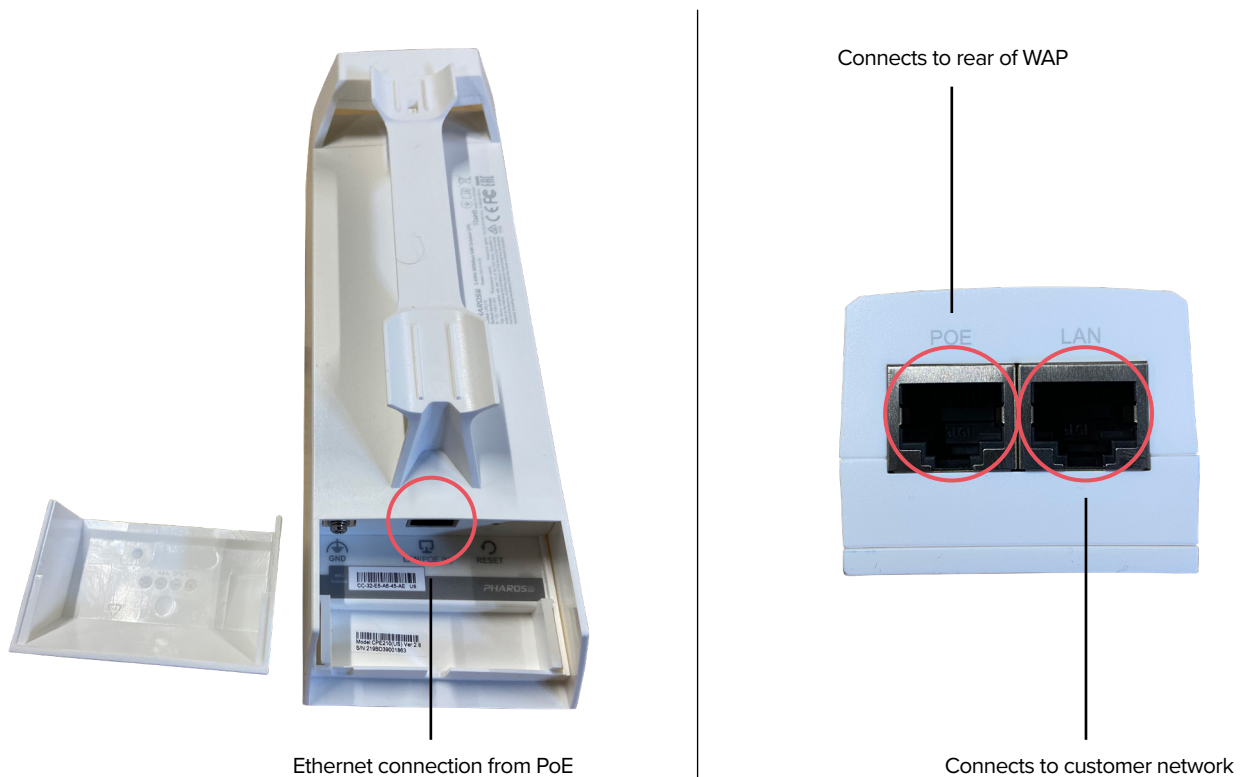

The other port on the PoE labeled LAN should be connected via Ethernet directly into the customer's existing network switch, router, or gateway. This cable length can be up to 300'.

Note: The WAP will **NOT** work if it is connected to a computer or laptop. If you have questions, please contact Cirrus Support.

Note: Pushing the reset button on the WAP erases all pre-configured settings, so it should never be done unless directed to by a member of Cirrus Tech Support.

Getting started: Digital Window Poster

Tools you will need

- 01. Drill or screwdriver with phillips head
- 02. Level (optional)

What's inside the box

	Item number	Item description	Item quantity
Mounting Tray Assembly	1	M1 Pro Controller	1
	2	Mounting Tray	1
	3	Black Oxide 18-8 stainless Steel Pan Head Phillips Screws	4
	4	Zinc Plated Steel Hex Nut	4
	5	Steel Hex Head Drilling Screws	7
Digital Poster and Mounting	1	Digital Window Poster	1
	2	Mounting Cables	2
	3	Power Cable	1
	4	Poster to Controller Cable Cover Sleeve (not pictured)	1
	5	External Hex Head Drilling Screws	6
Antennas	1	Orange Cellular Antennas	2
	2	Black WiFi Antennas	2
<p><i>Please refer to the diagrams on the next page for reference on parts.</i></p>			

What's inside the box (continued)

Mounting tray assembly

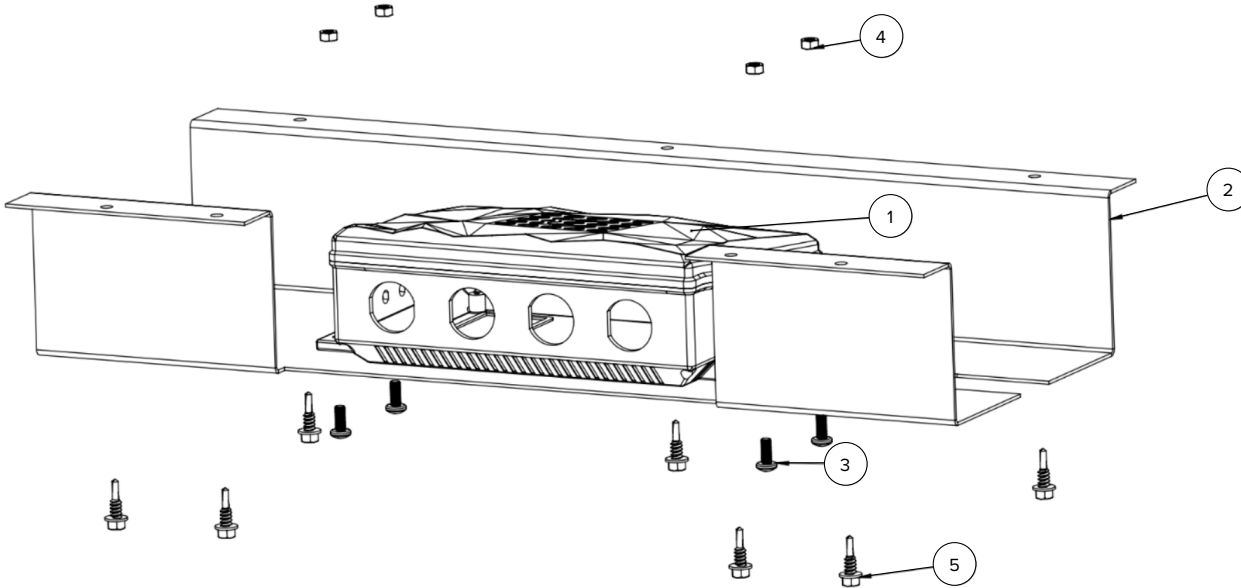

Digital Poster and mounting

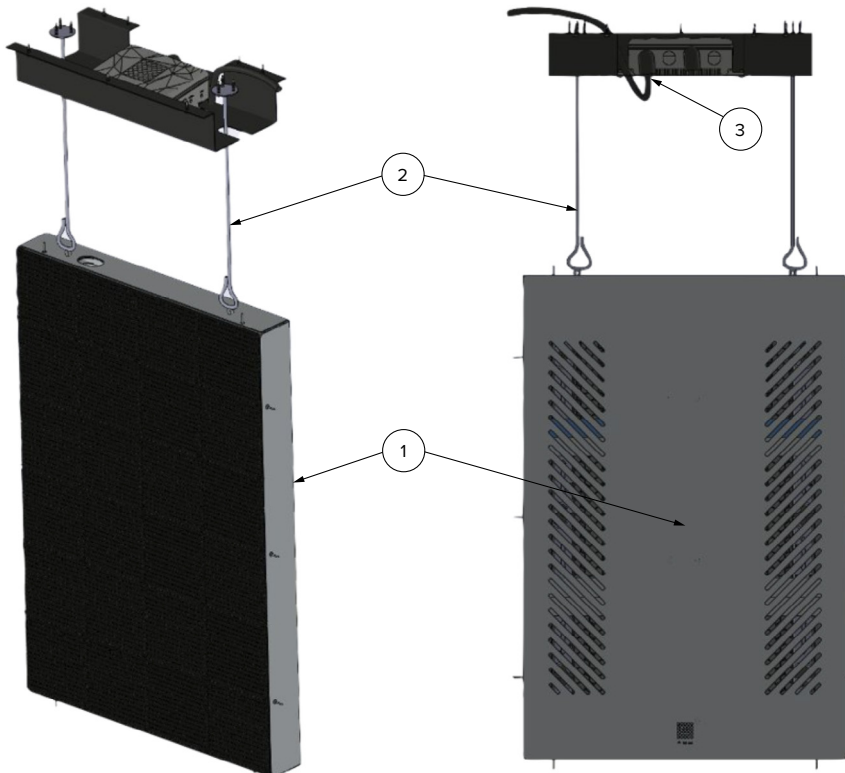

Mounting

If mounting in front of a window, ensure that there is a minimum distance of 3 inches between the window and the Digital Window Poster.

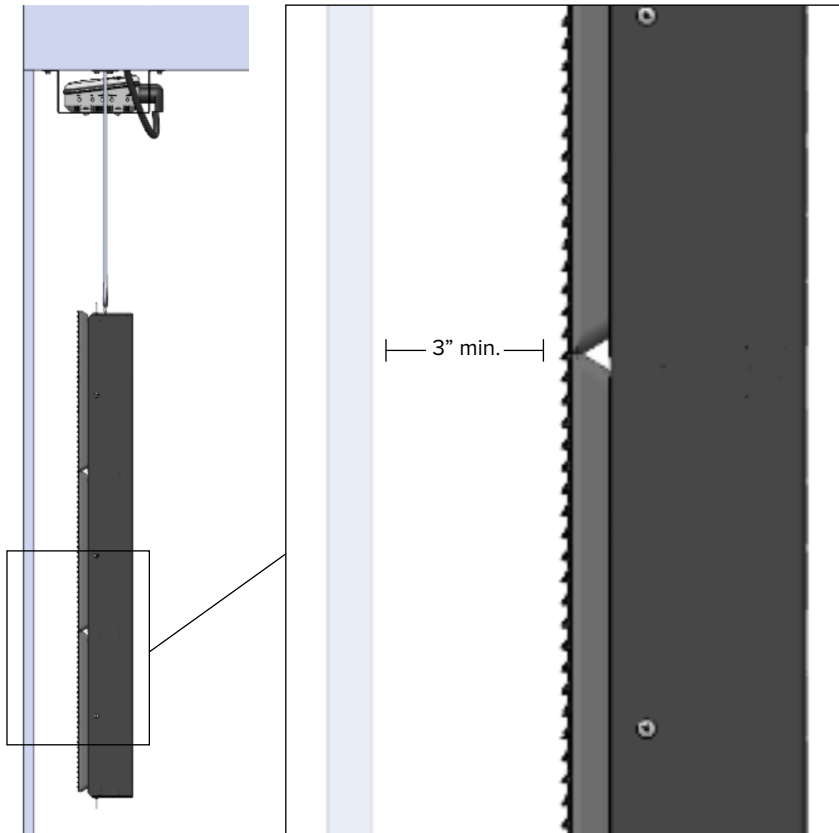

Mounting tray assembly

Step 01. Install Controller with the cables on the bracket

Step 02. Drill the 7 holes on the wall or the ceiling by electric dill

Step 03. Install the bracket with the controller on the wall or the ceiling*

*If there is a glass wall in front of the DWP, the minimum distance between the bracket and the glass wall is 25mm or 1 inch.

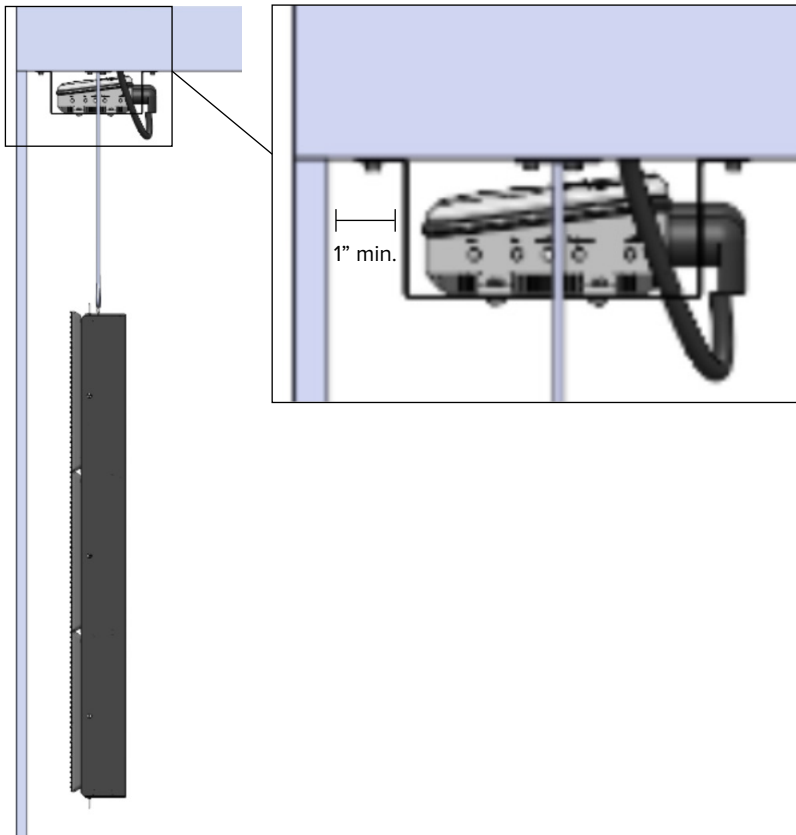
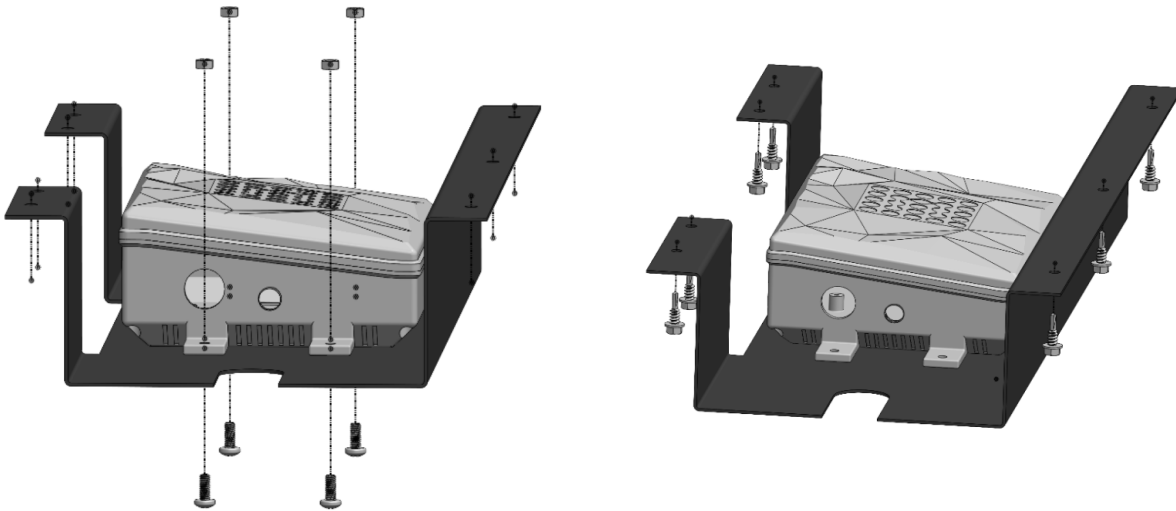

Mounting cables

Step 01. Drill the 3 holes for each mounting cable on the wall x inches apart*

Step 02. Install both mounting cable with provided screws

*Please make sure you are mounting into a stud or other secure surface.

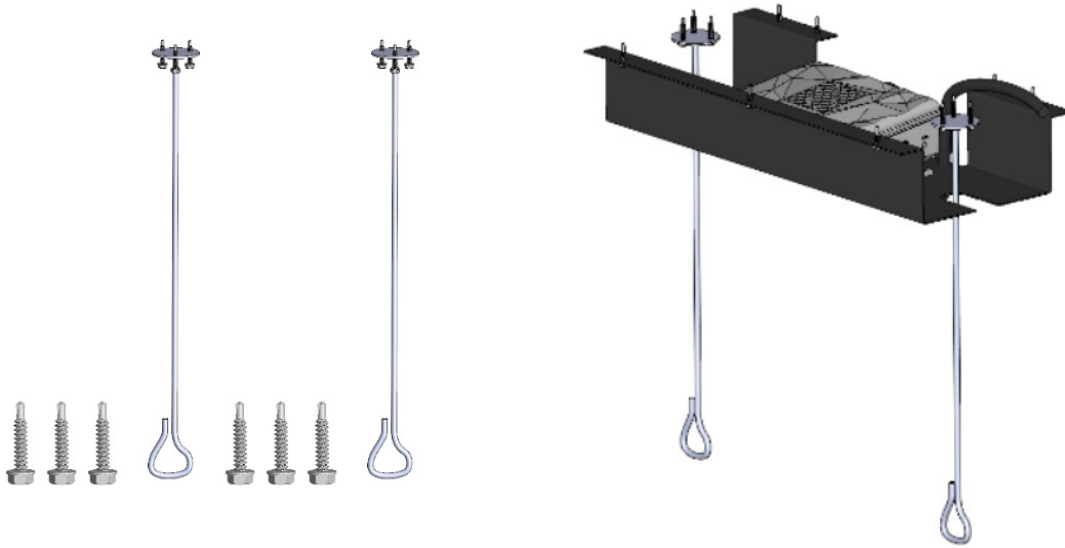

Mounting cables

Clip the Mounting Cable ends to the eye hooks on the top of the Digital Window Poster

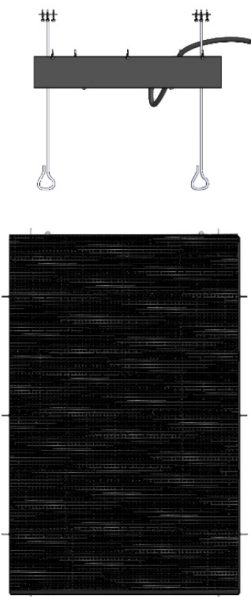

Making mounting cable adjustments

The mounting cables' lengths can be adjusted as necessary. A level is recommended to ensure the Digital Window Poster is level.

Plugging Digital Window Poster cable into controller

Snap the cable running from the Digital Window Poster Cable into the controller's port labeled "Data A". You should hear a click when it snaps into place.

Poster to controller cable cover sleeve

Optionally wrap hook-and-loop Cable Cover Sleeve sleeve around length of the Poster Cable and Mounting Cable.

Power on

Step 01. Plug Power Cable into port labeled "Power" on controller

Step 02. Plug Power Cable into wall outlet providing 110/120V 20AMP power.

Step 03. Hold the Silver Button on the controller for 5 seconds and release it when the light turns blue.

Step 04. There is a pause while the controller attempts to send mapping data to the panels.

Step 05. Once the automapping completes, a system check is initiated.

The sign will show a rainbow pattern, then a network status. These will alternate for 2 minutes or until the Button is pressed once quickly.



If the automapping process doesn't complete correctly, please reach out to **Cirrus Support at (877) 636-2331 option 2.**