

Contents

Introduction	1
Messaging software options	1
Related documentation	1
Controls and indicators	2
Technical specifications	4
Sign specifications	4
Temperature protection	4
EMI compliance	4
Safety information	5
General	5
Internal battery replacement	5
Sign configuration	6
Setting DIP switches	6
Speaker volume control	9
Using the IR remote control	10
Networking	13
RS232	13
RS485	14
Ethernet	14
Installation	18
Environmental requirements	18
Reducing electrical noise	18
Checking speaker volume	18
Wall mounting instructions	18
Ceiling mounting instructions	20
Counter mounting instructions	21
Checkout procedure	22
Service and maintenance	22
Firmware updates	22
Routine cleaning	22

Introduction

AlphaPremiere™ 9000 series signs are indoor, four-line, full matrix LED displays. These signs can display both text and graphics and can be networked together. Two speakers are built into the sign's right end cap.

External status LEDs monitor all communication data and provide self-diagnostic capability.

Messaging software options

To display text and graphics on an AlphaPremiere™ sign, some type of messaging software is required to create and to send messages. The following options are available:

- AlphaNET™ software
- Alpha® Messaging software
- Smart Alec® software
- Alpha® ActiveX® Marquee Control software
- Custom messaging software created using the Alpha® sign communications protocol

Related documentation

These documents are available at the Adaptive® web site (<http://www.adaptivedisplays.com>):

Document name	Part number	Description
AlphaNET™ User Manual	9708-8081	Allows the creation and scheduling of messages for display on signs.
Messaging Software User Manual	9701-0202	Basic sign messaging with a PC.
Smart Alec® User Manual	9709-2030	Intelligent messaging software with OPC Client
ActiveX® Developer's Reference	9709-2054	Explains how to use the Alpha® ActiveX® Marquee Control software.
Alpha® Sign Communications Protocol	9708-8061	Used to create custom messaging solutions.
Networking Alpha® Signs	9711-0112	Basic reference for networking Adaptive® signs.

Controls and indicators

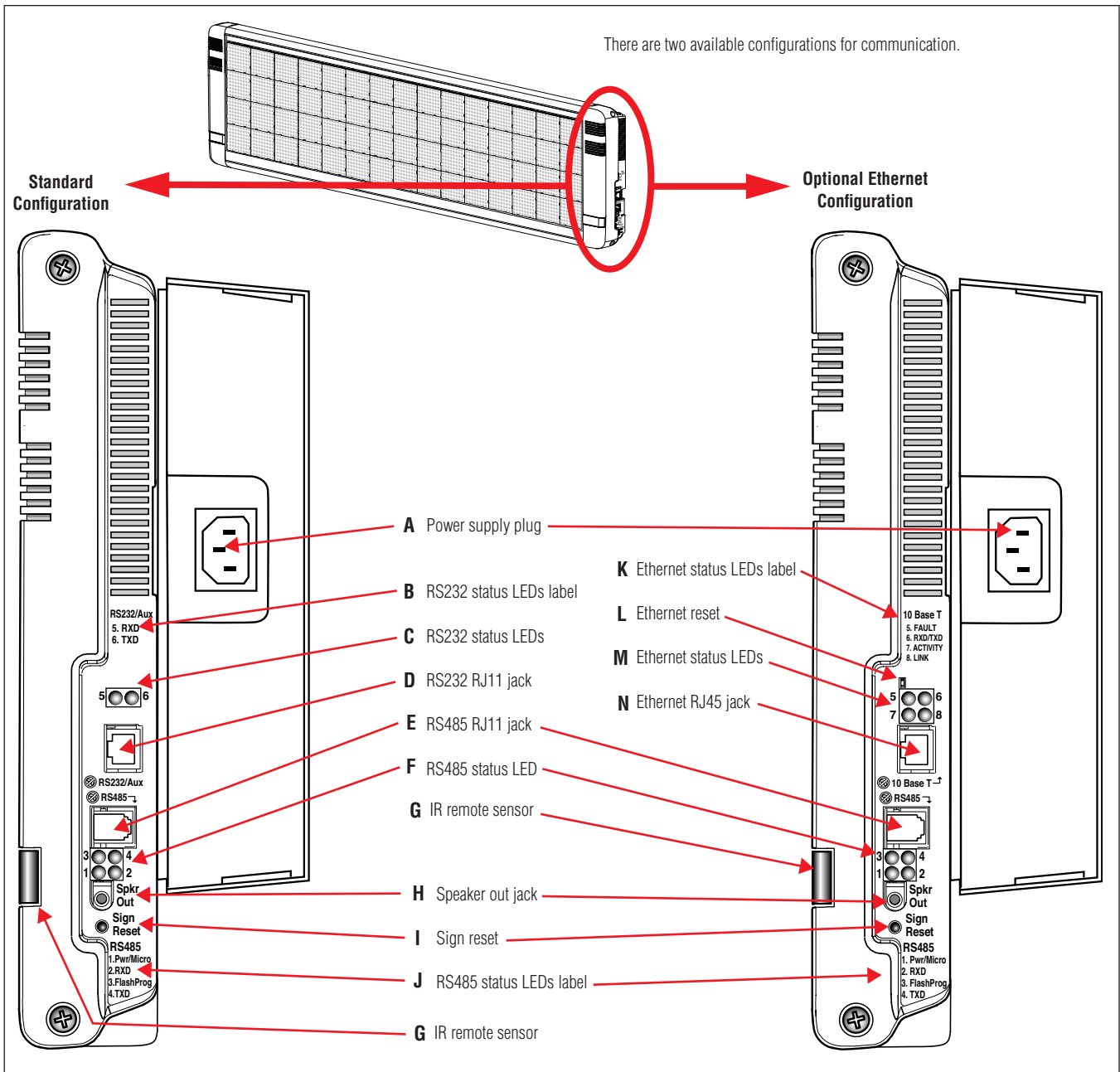

Item	Name	Description
A	Power supply plug	<p>The plug on the power supply cord serves as the disconnect device for this display. During mounting and installation of the display, make sure that the electrical power socket/outlet is easily accessible and that it is located close by the display.</p> <p>Français La fiche du cordon d'alimentation sert de dispositif de débranchement pour cet affichage. Lors du montage et de l'installation de l'affichage, assurez-vous que la prise d'alimentation électrique est facilement accessible et qu'elle se situe près de l'affichage.</p> <p>Deutsch Der Stecker am Netzteilkabel fungiert als Trennvorrichtung für dieses Anzeigeschild. Während der Montage und Installation des</p>
		<p>Schildes ist sicherzustellen, dass die Netzsteckdose leicht zugänglich ist und sich nahe am Schild befindet.</p> <p>Italiano La spina del cavo di alimentazione serve anche come dispositivo di scollegamento di questo display. Durante il fissaggio e l'installazione del display, accertarsi che la presa di corrente sia facilmente raggiungibile e sia situata vicino al display.</p> <p>Español La clavija del cable de alimentación sirve como dispositivo de desconexión para este anuncio. Durante el montaje y la instalación del anuncio, asegúrese de que el receptáculo/tomacorriente eléctrico quede fácilmente accesible y que esté ubicado cerca del anuncio.</p>

B	RS232 status LEDs label	Information label for RS232 LED status
C	RS232 status LEDs	RS232 communications status LEDs: <ul style="list-style-type: none"> • LED 5: TXD (Transmitted Data) • LED 6: RXD (Received Data)
D	RS232 RJ11 jack	RJ11 jack for RS232 data. This is NOT a telephone jack.
E	RS485 RJ11 jack	RJ11 jack for RS485 data. This is NOT a telephone jack.
F	RS485 status LEDs	RS485 communication status LEDs: <ul style="list-style-type: none"> • LED 1: Pwr/Micro <ul style="list-style-type: none"> - Blinking blue LED = ok. - If blue LED is steady or off, contact Adaptive® Technical Support. • LED 2: TXD (Transmitted Data) • LED 3: Flash Prog • LED 4: RXD (Received Data)
G	IR remote sensor	Receiving window for signals from the handheld Infrared Remote Control
H	Speaker out jack	Speaker out jack can connect to any self-powered external speaker (such as typical PC speakers). NOTE: A stereo plug must be used to connect external speakers. Using a mono plug could damage the sign.
I	Sign reset	Allows cycling through power-up messaging
J	RS485 status LEDs label	Information label for RS485 LED status
K	Ethernet status LEDs label	Information label for Ethernet LED status
L	Ethernet reset	Allows resetting Ethernet hardware
M	Ethernet status LEDs	Ethernet communication status LEDs: <ul style="list-style-type: none"> • LED 5 (red): FAULT — Blinks or lights red in combination with LED 6 to indicate diagnostics and error detection: <ul style="list-style-type: none"> Red solid and LED 6 blinking: <ul style="list-style-type: none"> - 1x = EPROM checksum error - 2x = RAM error - 3x = network controller error - 4x = EEPROM checksum error - 5x = duplicated IP address on the network (non-fatal error) - 6x = software does not match hardware (non-fatal error) Red blinking and LED 6 blinking: <ul style="list-style-type: none"> - 4x = faulty network connection (non-fatal error) - 5x = no DHCP response received (non-fatal error) • LED 6 (green): RXD/TXD — Solid green indicates idle. Blinking indicates transmission/reception. • LED 7 (yellow): ACTIVITY — Solid yellow indicates idle. Blinking indicates a network connection. • LED 8 (green): LINK — Solid green indicates network port connected to the network.
N	Ethernet RJ45 jack	RJ45 jack for Ethernet connection

Technical specifications

Sign specifications

Sign model	LED columns	LED rows	LED color	Dimensions (L x W x H)	Weight (approx)	Input voltage (VAC)	Input current	
							@ 100 VAC	@ 240 VAC
9080	80	32	Tricolor	28 x 2.2 x 12 (in) 71.1 x 5.59 x 30.5 (cm)	18 (lb) 8.2 (kg)	100 - 240 @ 50 - 60 Hz	2.0 amps	1.0 amps
9120	120	32		40 x 2.2 x 12 (in) 101.6 x 5.59 x 30.5 (cm)	23 (lb) 10.4 (kg)		3.0 amps	1.5 amps
9160	160	32		52 x 2.2 x 12 (in) 132.1 x 5.59 x 30.5 (cm)	31 (lb) 14.1 (kg)		3.6 amps	1.8 amps
9200	200	32		64 x 2.2 x 12 (in) 162.6 x 5.59 x 30.5 (cm)	36 (lb) 16.3 (kg)		4.0 amps	2.0 amps
9240	240	32		76 x 2.2 x 12 (in)	41 (lb)		5.0 amps	2.5 amps
				193 x 5.59 x 30.5 (cm)	18.6 (kg)			

Temperature protection

The AlphaPremiere™ 9000 sign includes automatic temperature controls to determine when the internal temperature of the sign is too hot to continue normal operation. While the temperature controls are based primarily on the internal temperature of the sign, they are also affected by both ambient temperature and the sign’s load and its duration. So the higher the ambient temperature and the more LEDs that are on and the longer they are on, the higher the internal temperature.

Trigger temperature levels may vary from sign to sign, but in general the functioning is:

- As the temperature of the sign rises, cooling fans are switched on. If the temperature falls below the cooling fan threshold level, the cooling fans are turned off.
- If, however, the temperature of the sign continues to rise, auto-dimming occurs. This means that the LED output from the sign is forced into a reduced power mode, effectively dimming the brightness of the LEDs. If the temperature falls below the auto-dimming threshold level, then auto-dimming stops and the LED brightness returns to normal level.

EMI compliance

This equipment has been tested and found to comply with the limits for a Class A digital device, pursuant to Part 15 of the FCC Rules. These limits are designed to provide reasonable protection against harmful interference when the equipment is operated in a commercial environment.

This equipment generates, uses, and can radiate radio frequency energy and, if not installed and used in accordance with installation guidelines, may cause harmful interference to radio communications. Operation of this equipment in a residential area is likely to cause harmful interference, in which case the user will be required to correct the interference at his own expense.





WARNING: This is a Class A product. In a domestic environment this product may cause radio interference, in which case the user may be required to take adequate measures.

Safety information

General

▲ WARNING	
	Possible fire hazard. Always mount unit indoors. Mounting the unit outdoors may cause a fire which could result in serious injury or death.

▲ WARNING	
	Possible shock hazard. Always mount unit indoors. Mounting a unit outdoors makes the unit a possible source of electric shock which could result in serious injury or death.

▲ WARNING	
	Hazardous voltage. Contact with high voltage may cause death or serious injury. Always disconnect power to sign prior to servicing.

▲ WARNING	
	Possible crush hazard. The wall and the mounting system must be able to support at least 4 times the unit's weight. Otherwise the unit may fall, causing serious injury or death.

Internal battery replacement

The AlphaPremiere™ 9000 sign uses an internal battery to store and retain message data when the power supply to the sign is disconnected. If the battery fails while the sign remains connected to a reliable source of power, you will not become aware of the battery failure until the power supply is lost or interrupted.

NOTE: Backup batteries are soldered in place and should only be replaced by a qualified technician.

If you suspect that your internal backup battery may have failed, please contact Adaptive® Technical Support.

▲ WARNING	
	Danger of explosion if battery is incorrectly replaced. Replace only with the same or equivalent type recommended by the manufacturer. Dispose of used batteries according to the manufacturer's instructions.

▲ AVERTISSEMENT	
	Il y a danger d'explosion s'il y a un remplacement incorrect de la batterie. Remplacer uniquement avec une batterie du même type recommandé par le fabricant. Mettre au rebut les batteries usagées conformément aux instructions du fabricant.

▲ AVVERTENZA	
	La sostituzione errata della batteria può comportare il pericolo di esplosione. Sostituire unicamente con una batteria identica o di tipo equivalente consigliata dal fabbricante. Eliminare le batterie scariche in base alle istruzioni del fabbricante.

▲ WARNUNG	
	Bei einem nicht vorschriftsgemäßen Austausch der Batterie besteht Explosionsgefahr. Nur durch eine Batterie des gleichen oder eines gleichwertigen, vom Hersteller empfohlenen Typs ersetzen. Gebrauchte Batterien gemäß Herstelleranweisung entsorgen.

▲ ADVERTENCIA	
	Existe el peligro de explosión si la batería se reemplaza incorrectamente. Reemplácela sólo con el mismo tipo de batería o uno equivalente recomendado por el fabricante. Deseche las baterías usadas de acuerdo con las instrucciones del fabricante.

Sign configuration

Before installing a sign, you may want to change one or more of the sign's default settings by changing DIP switches inside the sign.

To access and change DIP switches, follow these steps:

Setting DIP switches

1. Remove power from the sign.
2. If the sign is mounted, remove it and place the sign on a flat surface.
3. Remove the two (2) screws from the end cap located on the right side of the sign. Then remove the endcap:

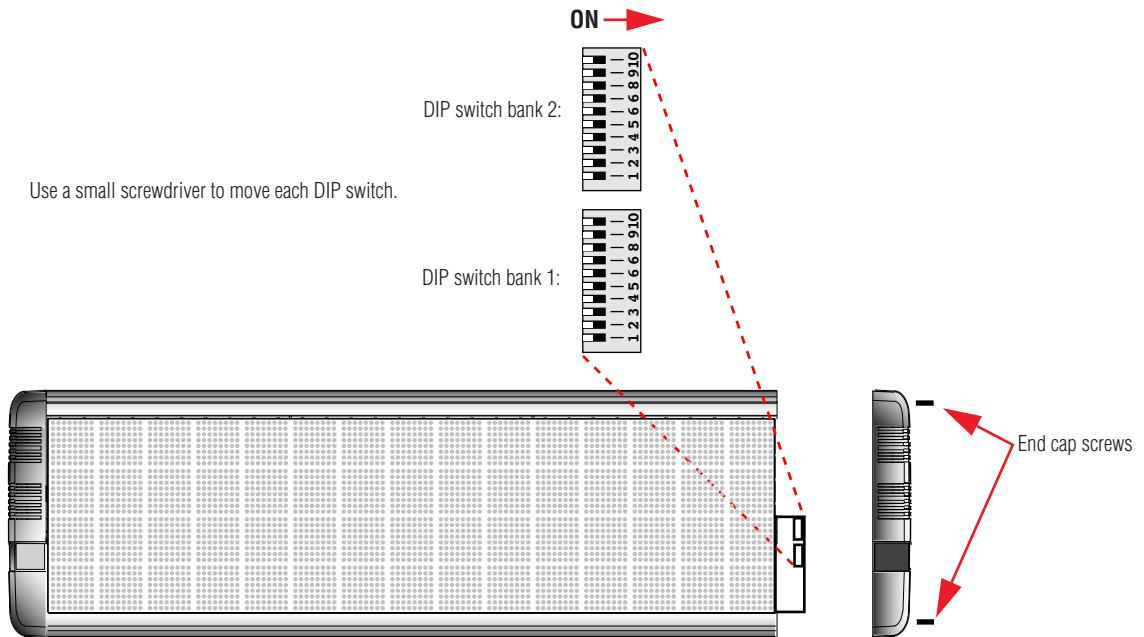

4. See the pages following to make changes in these functions (see "Bank 1 and Bank 2 DIP switches" on page 7):
 - EOL termination
 - Baud rate
 - RS485 echo
 - IR remote disable
 - Demonstration messages
 - Memory clear
 - Serial address
 - Data format
 - Diagnostics
5. After making the appropriate DIP switch changes, re-attach the end cap. Tighten the end cap screws to 14 lb-in, 1.58 Nm.

Bank 1 and Bank 2 DIP switches

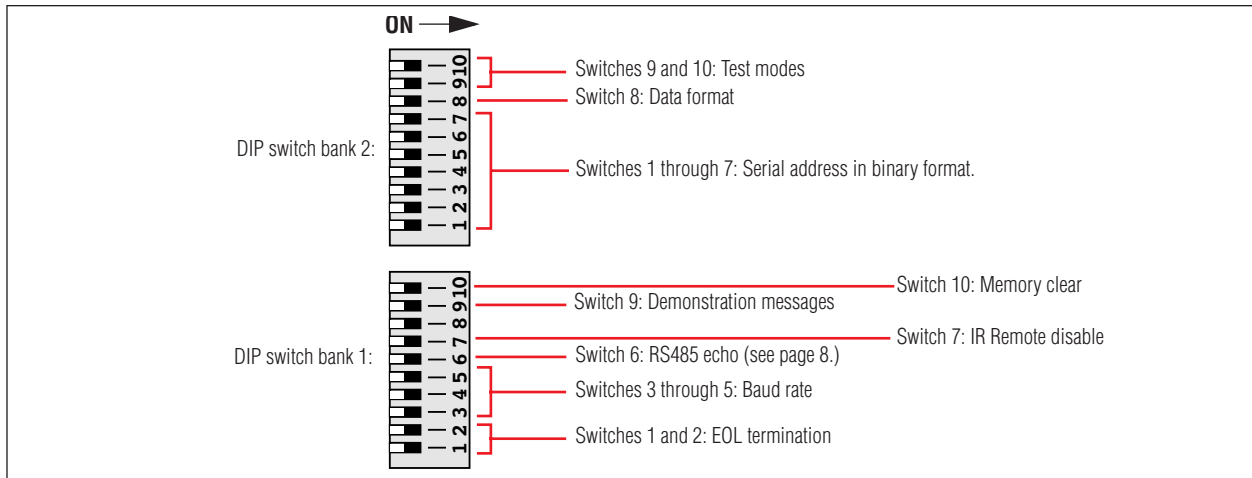

Bank 1 DIP switches

EOL termination	1	2
Set end-of-line termination off (default)	0	0
Set end-of-line termination on	1	1

Baud rate	3	4	5
Autobaud (default)	0	0	0
1200	1	0	0
2400	0	1	0
4800	1	1	0
9600	0	0	1
19200	1	0	1
38400	0	1	1
Autobaud	1	1	1

RS485 echo (see page 8.)	6
Disable RS485 echo (default)	0
Enable RS485 echo	1

IR remote disable	7
IR remote control can be used to change a sign's parameters (default)	0
IR remote control cannot be used to change a sign's parameters	1

Demonstration messages	9
Enable demo messages (default)	0
Disable demo messages	1

Memory clear	10
Do not clear messages at power-up (default)	0
Clear all messages at power-up	1

Bank 2 DIP switches

Serial address (address 0 = default) LSB = Least Significant Bit; MSB = Most Significant Bit								
Dec	Hex	LSB 1	2	3	4	5	6	MSB 7
0	00	0	0	0	0	0	0	0
1	01	1	0	0	0	0	0	0
2	02	0	1	0	0	0	0	0
3	03	1	1	0	0	0	0	0
.
.
.
125	7D	1	0	1	1	1	1	1
126	7E	0	1	1	1	1	1	1
127	7F	1	1	1	1	1	1	1

Data format	8
8N1 = 8 data bits, no parity, 1 stop bit (default)	0
7E2 = 7 data bits, even parity, 2 stop bits	1

NOTE: For Ethernet, when you change the Data format using DIP switches, a similar change must be made to the Data format of the internal Ethernet card. (See "Setting Baud rate and Data format on an Ethernet-equipped sign" on page 17.)

Test modes	Description	9	10
Run normal messages (default)	Normal messaging enabled	0	0
Test pattern	Test for unlit LEDs	1	0
LED test mode	Test for dim LEDs	0	1
Reserved for future use		1	1

RS485 echo (default = RS485 ECHO DISABLED)

When RS485 echo is enabled, incoming data (from either RS232 or Ethernet) is echoed or sent out the RS485 jack:

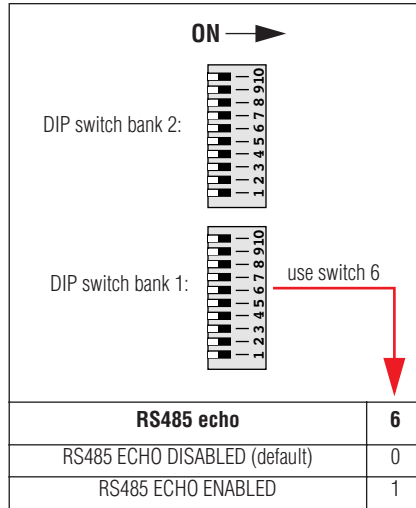

RS485 echo is useful when connecting multiple signs together because it can eliminate the need to use a Converter Box III:

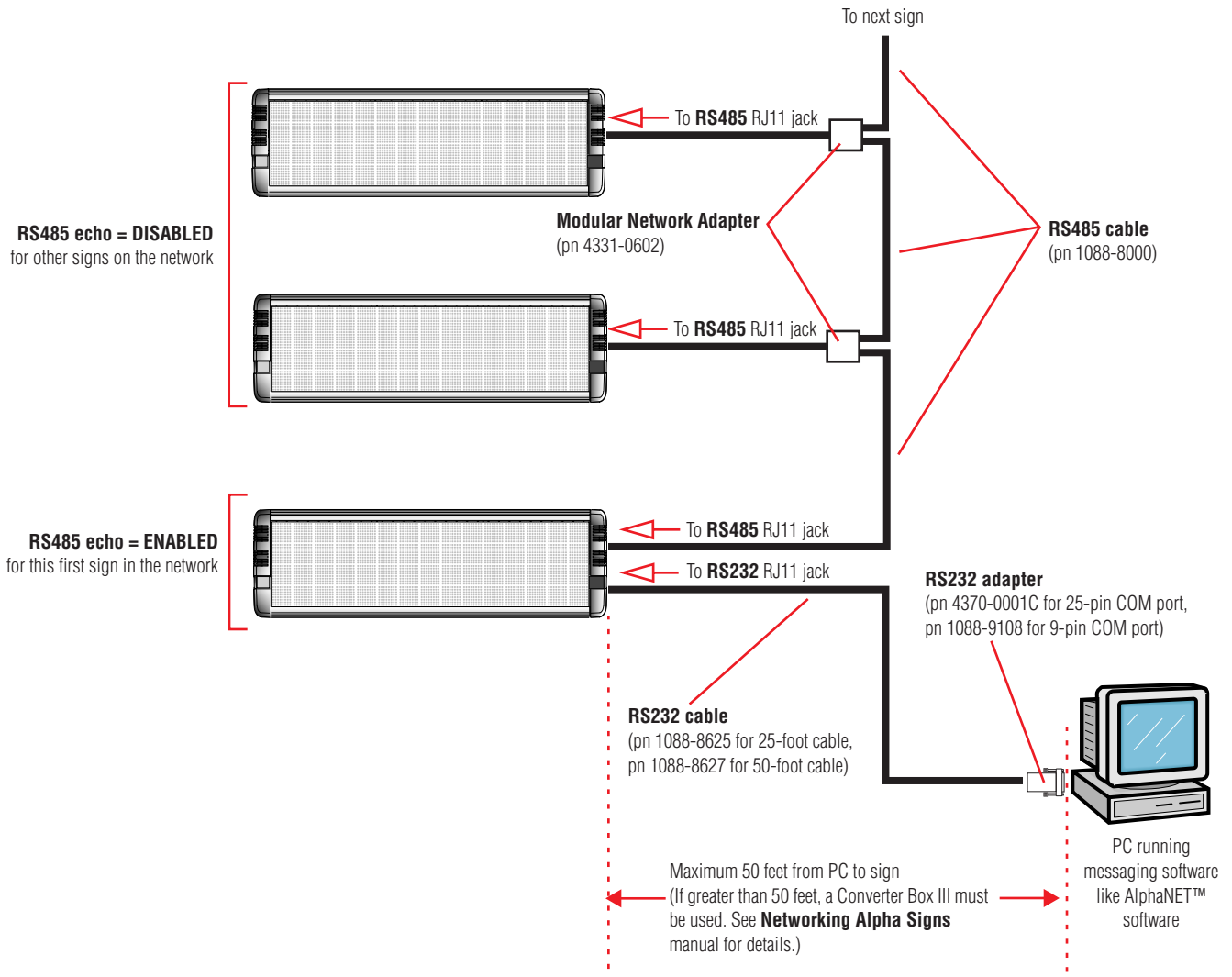

Speaker volume control

The AlphaPremiere™ 9000 sign has two internally-mounted speakers in the right end cap. Audio volume can be raised or lowered:

- temporarily by using the IR remote control (the “U” key raises volume, the “D” key lowers it), or
- permanently by changing an internal master volume dial (see below).

NOTE: Also, the duration and number of repetitions of audio tones can be set using AlphaNET™ software. (See the “Site Manager” section of the **AlphaNET™ User Manual**.)

To change the default volume setting, follow these steps:

1. Remove power from the sign.
2. If the sign is mounted, remove it and place the sign face down on a flat surface.
3. Remove the two (2) screws from the end cap located on the left side of the face down sign. Then remove the end cap:

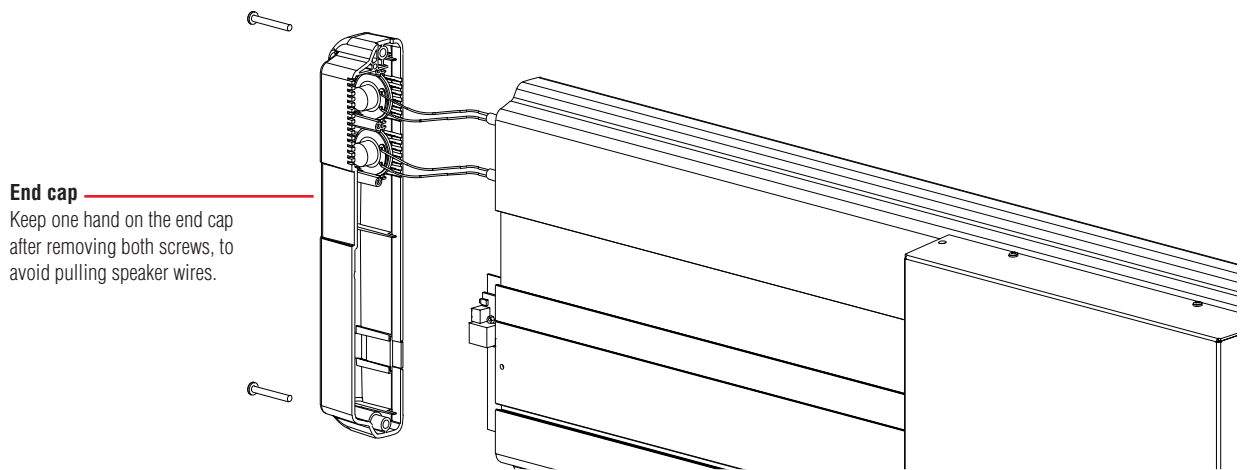

4. To change the default factory volume setting, use a screwdriver to turn the dial clockwise to raise the volume or counterclockwise to lower the volume. (It is recommended that you use a plastic screwdriver, not a steel screwdriver, to make the adjustment.) The default factory setting is maximum.

NOTE: To turn on a continuous repeated tone for volume adjustment, use the IR remote control as described in “Using the IR remote control” on page 10. When you get to *Volume*, you’ll be able to hear the speaker volume increase and decrease as the adjustable dial is rotated. However, this is a *temporary* setting only.

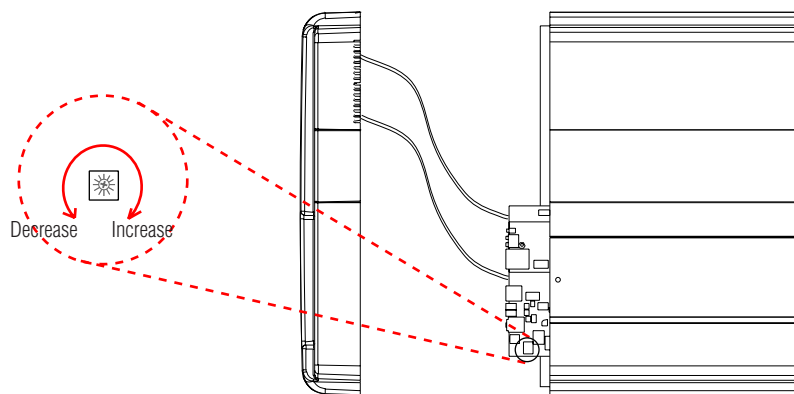

- 5. For remote audio connections or to boost volume output, a stereo speaker plug can be connected to the Speaker out jack. Use DC inline speakers of the type used to improve output from a personal computer.

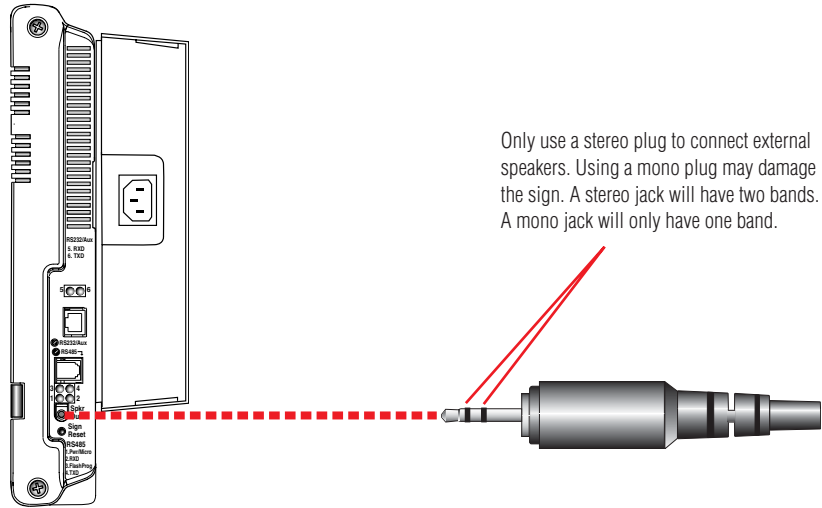

Using the IR remote control

The IR remote control is used to set up and test an AlphaPremiere™ sign. However, messages cannot be programmed into an AlphaPremiere™ 9000 sign using a remote control.

Most of the keys on the IR remote control are not usable with an AlphaPremiere™ 9000 sign. The illustration below shows the remote control keys that can be used:

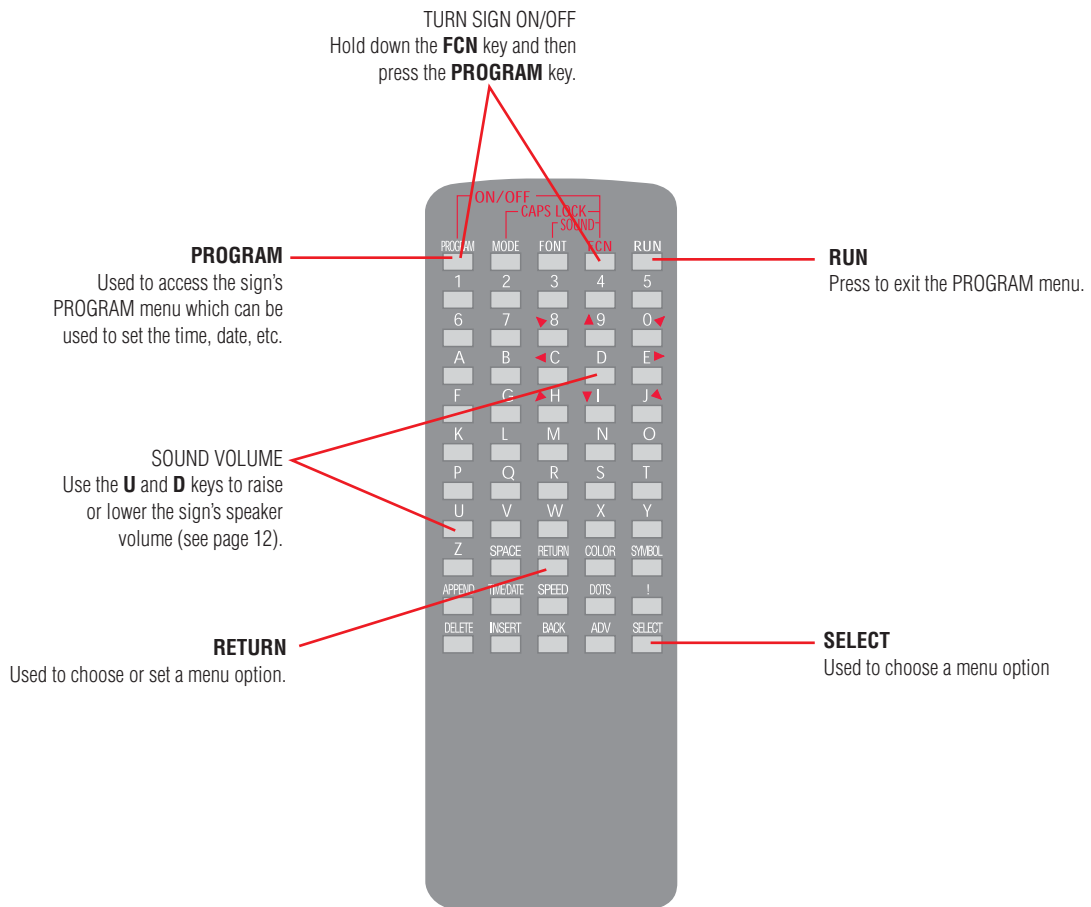

Setting time

When you press this . . .	You'll see this on the sign . . .
PROGRAM key	PROGRAM
SELECT key	TURN OFF
SELECT key	RUN DEMO/TIME
SELECT key	SET TIME
RETURN key Press the RETURN key until the desired hour appears.	HOUR
SELECT key Press the RETURN key until the desired minutes appears.	MIN
SELECT key Press the RETURN key to select either a 12-hour or a 24-hour time display format.	12HR or 24HR
Then press the RUN key.	

Setting date

When you press this . . .	You'll see this on the sign . . .
PROGRAM key	PROGRAM
SELECT key	TURN OFF
SELECT key	RUN DEMO/TIME
SELECT key	SET TIME
SELECT key	SET DATE
RETURN key Press the RETURN key until the desired month appears.	MONTH
SELECT key Press the RETURN key until the desired date appears.	DATE
SELECT key Press the RETURN key until the desired year appears.	YEAR
SELECT key Press the RETURN key until the desired day appears.	WEEKDAY
Then press the RUN key.	

Clearing memory

When you press this . . .	You'll see this on the sign . . .
PROGRAM key	PROGRAM
SELECT key	TURN OFF
SELECT key	RUN DEMO/TIME
SELECT key	SET TIME
SELECT key	SET DATE
SELECT key Press the RETURN to clear all messages from the sign's memory.	CLEAR MEMORY
The sign will display the information in "Checkout procedure" on page 22. Then the sign will go blank.	

Test menu

When you press this . . .	You'll see this on the sign . . .
PROGRAM key	PROGRAM
SELECT key	TURN OFF
SELECT key	RUN DEMO/TIME
SELECT key	SET TIME
SELECT key	SET DATE
SELECT key	CLEAR MEMORY
SELECT key	TEST MENU
RETURN key Selects WATCHDOG test.	WATCHDOG
RETURN key Runs the WATCHDOG test.	Information in "Checkout procedure" on page 22.
After running the test, the sign will display the messages that are programmed in it.	

Setting sound volume

When you press this . . .	You'll see this on the sign . . .
PROGRAM key	PROGRAM
SELECT key	TURN OFF
SELECT key	RUN DEMO/TIME
SELECT key	SET TIME
SELECT key	SET DATE
SELECT key	CLEAR MEMORY
SELECT key	TEST MENU
RETURN key	WATCHDOG
SELECT key This is for diagnostics only. Do not use this setting.	DIP
SELECT key	VOLUME
Press the U key to turn volume up. Press the D key to turn volume down. The "00" shown here changes accordingly. NOTE: This is a <i>temporary</i> setting only. It can be used as described in "Speaker volume control" on page 9.	VOLUME = 00
SELECT key	TEST MENU
RUN key	The messages that are programmed in the sign.

Networking

AlphaPremiere™ 9000 series signs can be connected together so that messages can be sent to each of the signs on the network. There are three ways to network AlphaPremiere™ 9000 series signs:

- RS232 (only available with the Standard Configuration) — This type of sign network allows “point-to-point” communication. This means that a single PC can be connected to a single sign. The length of this network is limited to 50 feet.
- RS485 (available with both Standard and optional Ethernet Configurations) — This type of sign network permits communication to a single or to multiple signs. The length of this network can be 4000 feet at 9600 baud.
- Ethernet (only available with the optional Ethernet Configuration) — This sign network allows connection of almost an unlimited number of signs over a virtually unlimited network length.

RS232

The diagram below shows how to connect a sign to your PC, through the PC’s RS232 jack. The PC cannot be separated from the sign by more than 50 feet because of signal loss in the cable:

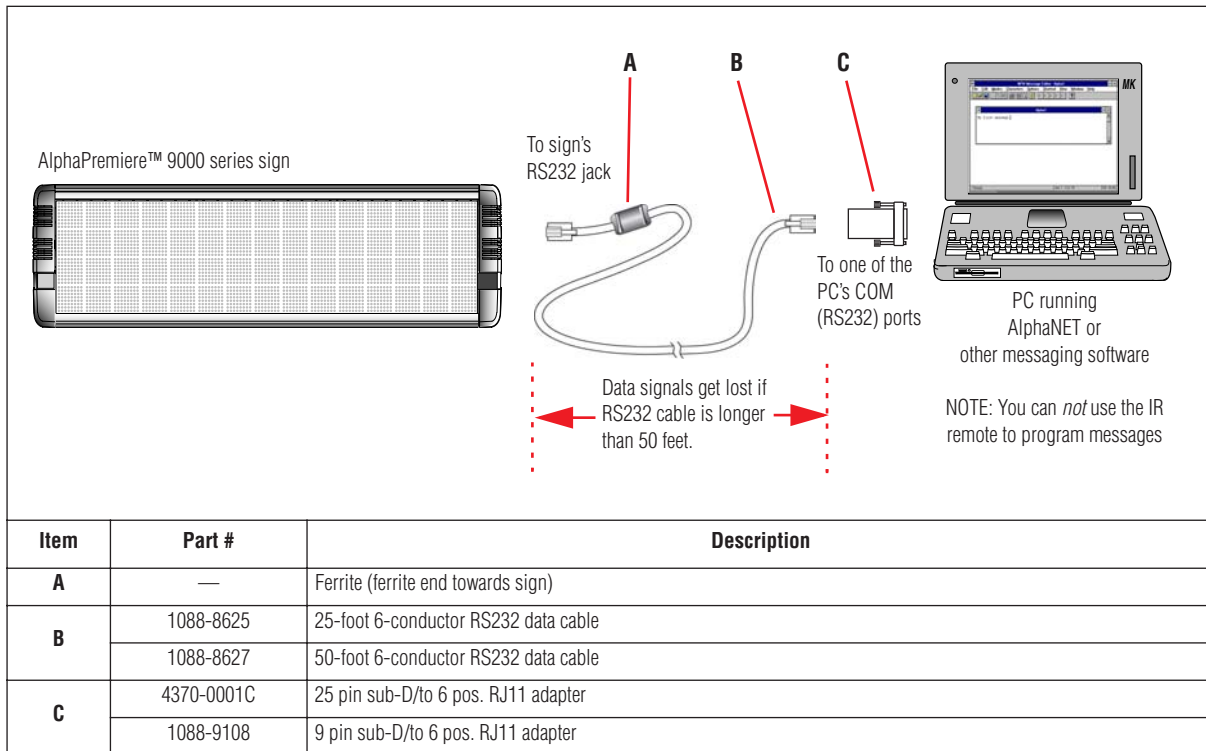

RS485

Refer to the **Networking Alpha Signs** manual for information on cabling requirements and connecting multiple signs.

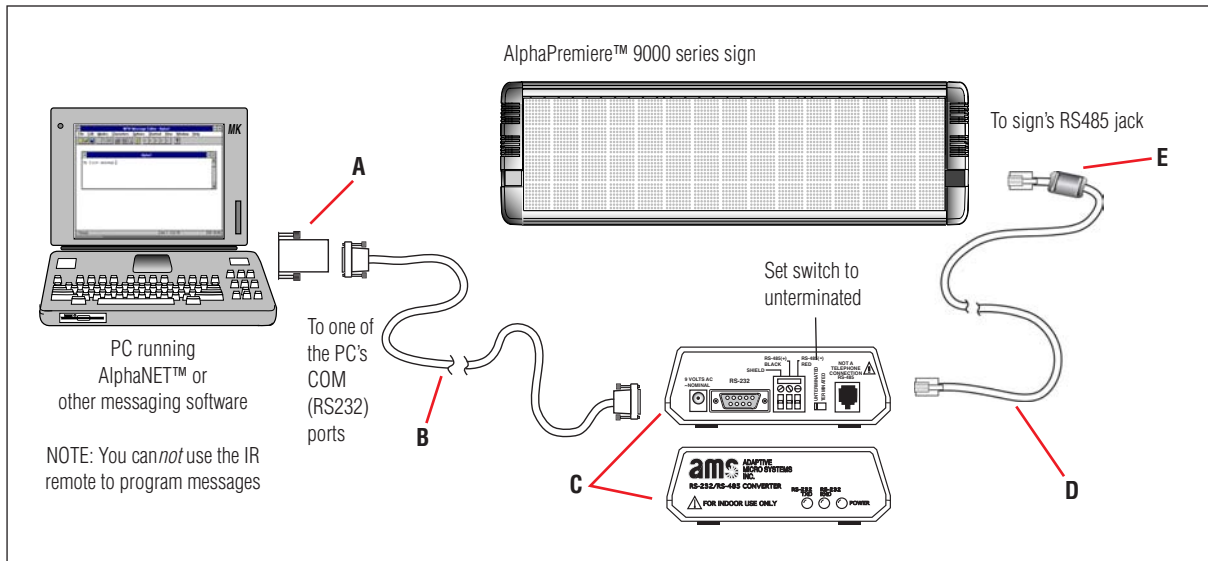

Item	Part #	Description
A	4370-0001C	25 pin sub-D/to 6 pos. RJ11 adapter
	1088-9108	9 pin sub-D/to 6 pos. RJ11 adapter
B	1088-8634	10-foot 9-pin to 9-pin, type "A9" RS232 data cable (Other lengths available)
C	1088-1111	Converter Box III
D	1088-8000	4-conductor RS485, bulk cable
E	1088-8624	8 foot, 4-conductor RS485 cable, ferrite end closer to sign
	1088-8636	1 foot, 4-conductor RS 485 cable, ferrite end closer to sign

Ethernet

NOTE: A network administrator should be involved in connecting the sign to the Ethernet.

The optional configuration for the AlphaPremiere™ 9000 sign includes an internal 10BASE-T Ethernet card with an external RJ45 jack. An IP address must be assigned to a sign. See "Setting a sign's TCP/IP address" on page 15.

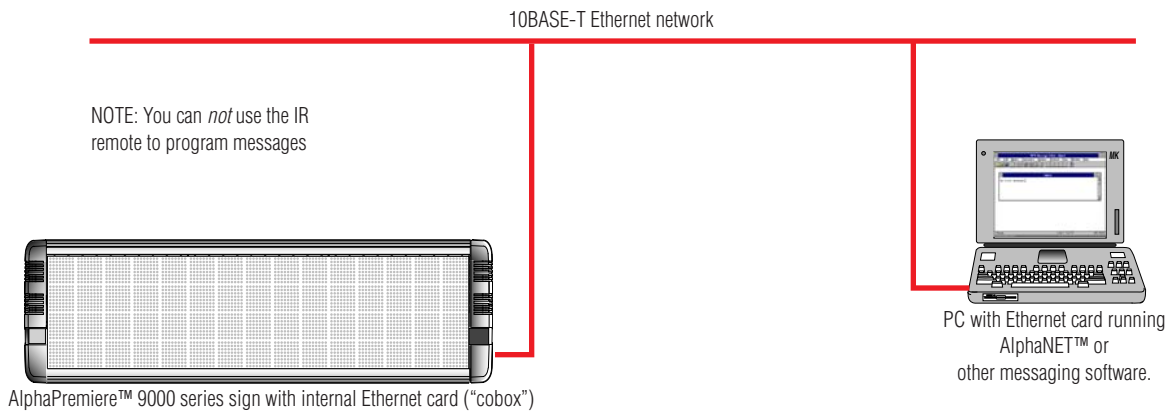

Setting a sign's TCP/IP address

Before you can begin to use an AlphaPremiere™ 9000 sign on an Ethernet network, the display must be assigned a unique TCP/IP address.

NOTE: The Alpha® Ethernet option inside the display is shipped with a default address of 010.11.11.1.

To set a new IP address, follow these steps:

1. Get a unique IP address from your network administrator. An example of an IP address is: 10.67.12.21.
2. Write down the 6-digit *Ethernet address* found on the Ethernet option label on the *back* of a sign. For example, the *Ethernet address* for the following label is: 00-20-4A-54-09-C8.

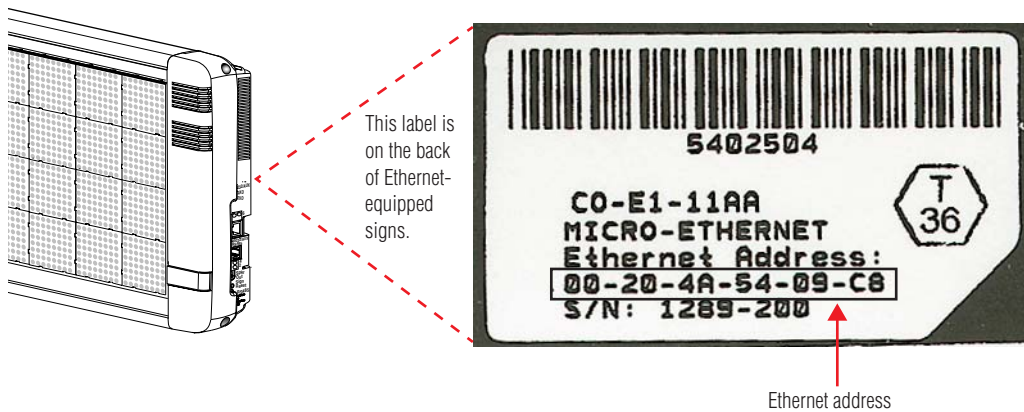

3. Using the Configuration Utility software supplied with the sign, select *Tools > Assign IP . . .*:

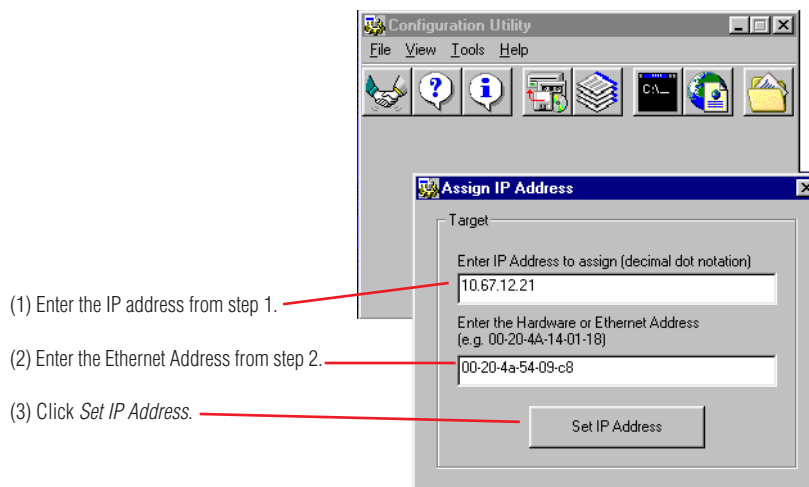

4. Next, select *Tools > Ping Device . . .*, enter the sign's IP address, and click *Ping* to make certain that the IP address you just assigned works.

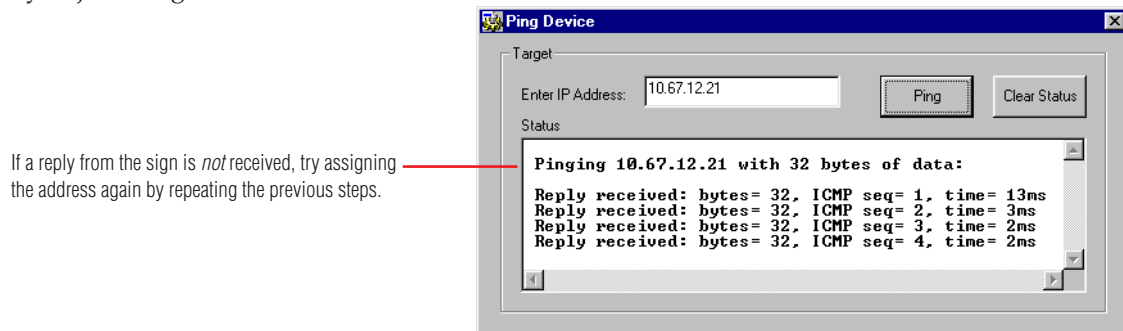

5. After the sign has an IP address assigned to it:

- select *Tools > Query Device . . .* to get information about the sign's Ethernet status:

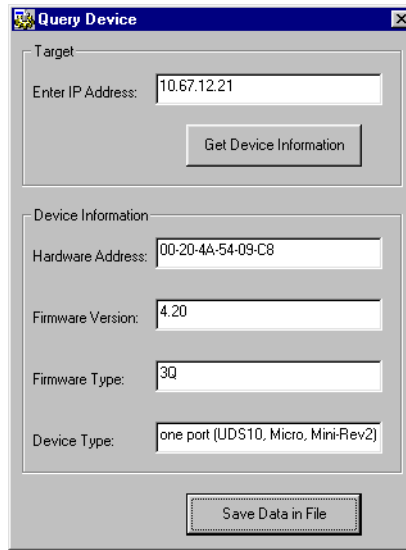

- select *Tools > Telnet to Device . . .* to set various Ethernet parameters:

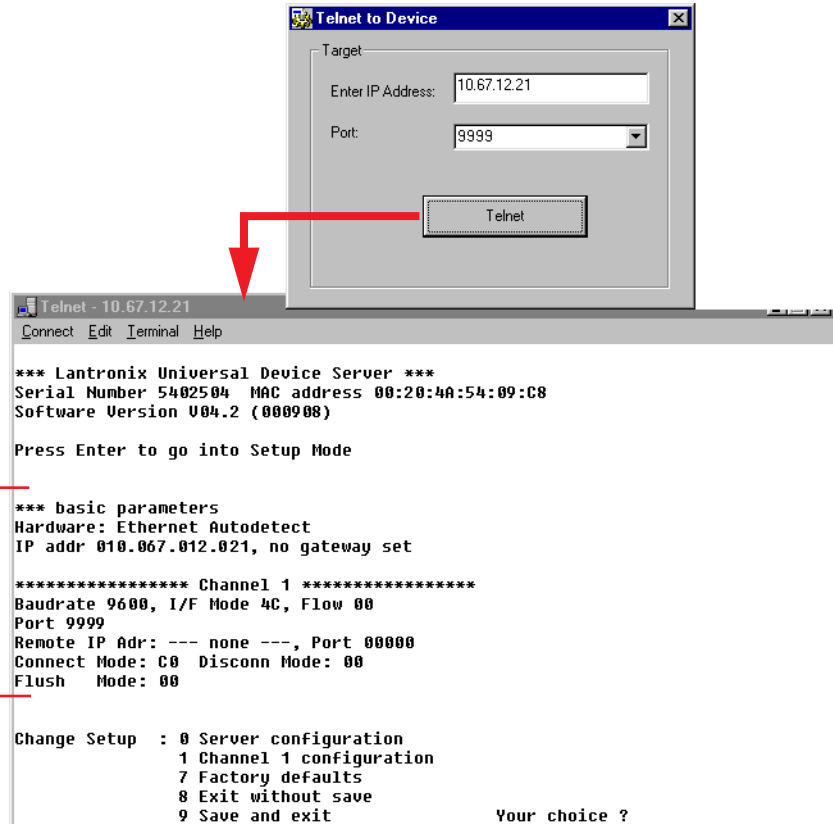

Baudrate, I/F Mode, Flow, Port,
etc. are all *Channel 1* parameters.

Typically, you would only need to
set the *Baudrate* and *I/F Mode*
parameters.

Setting Baud rate and Data format on an Ethernet-equipped sign

On signs that are Ethernet equipped, the baud rate and data format of the sign’s internal Ethernet card *must be identical* to the baud rate and data format of:

- the sign’s internal DIP switches. See “Sign configuration” on page 6.
- the computer that is running the messaging software used to send messages to the sign.

To change the baud rate and data format of the sign’s internal Ethernet card, follow these steps:

1. Using the Configuration Utility software supplied with the sign, select *Telnet to Device*. The current baud rate, data format (called *I/F Mode*), and other communication parameters will appear:

Parameters of the sign’s internal Ethernet card:

- *Baudrate 9600* – Factory setting. Can be changed.
- *I/F Mode* (see table below) – This is a hexadecimal number (4C in this example) that sets the network type (RS232, internal to the sign), number of data bits (7/8), parity (None/Odd/Even), and number of stop bits (1/2).

Data format (I/F Mode) table

Option		Binary Code								
		7	6	5	4	3	2	1	0	
Network Type	RS232								0	0
Number of Data Bits	7 bit					1	0			
	8 bit					1	1			
Parity	None			0	0					
	Even			1	1					
	Odd			0	1					
Number of Stop Bits	1 bit	0	1							
	2 bits	1	1							

Examples:

Options	Binary Code	Hexa-decimal Number
RS232, 8-bit, No parity, 1 stop bit	01001100	4C
RS232, 7-bit, Even parity, 1 stop bit	01111000	78

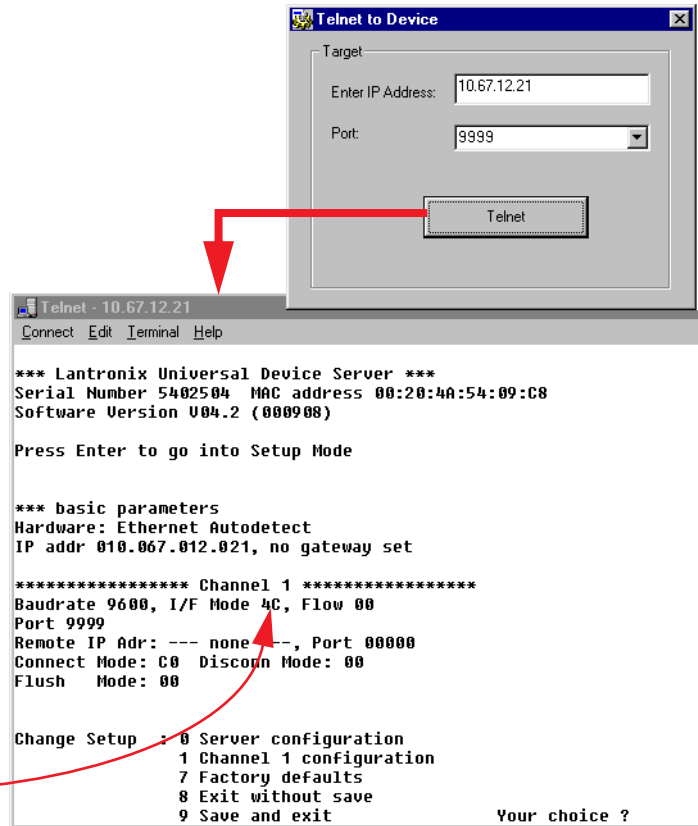

2. Select *1* for *Channel 1 Configuration*. Then set the various parameters as you are prompted:

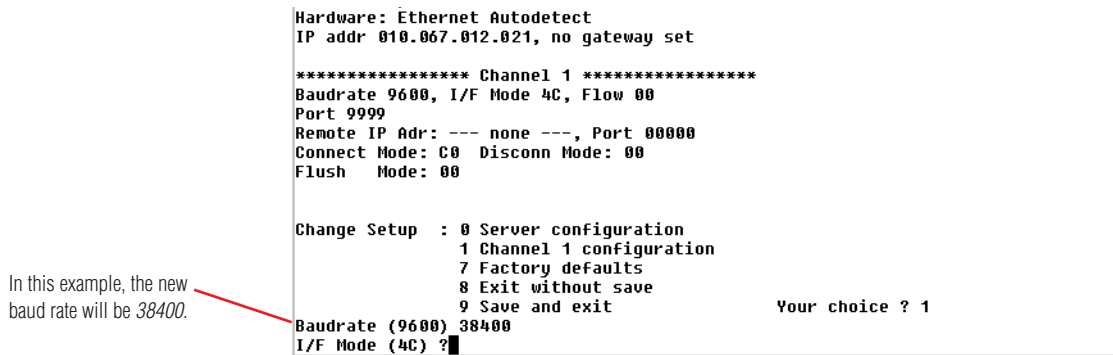

In this example, the new baud rate will be 38400.

Installation

Environmental requirements

Care must be taken to observe these considerations when selecting a location for the sign.

- These signs are for *indoor use only* and should not be continuously exposed to direct sunlight.
- These signs should only be used in an environment where the temperature is between 0 and 50 degrees Celsius (32° to 122° F).
- These signs should only be used in an environment where the humidity (non-condensing) does not exceed 95%.
- For installation, there must be at least 1" (2.5 cm) clearance on each end of the case and at least 2" (5.1 cm) clearance above the case.

Reducing electrical noise

These procedures are recommended to decrease the amount of electrical emissions and noise with the AlphaPremiere™ 9000 signs:

- A sign should be connected to its own branch circuit.
- The input power source should be protected by a circuit breaker rated at no more than 20 amperes, with no more than 4 signs connected together through a single circuit breaker.
- Incoming power to a sign should be routed on a path separate from a sign's serial communication wires. Do NOT run the power and communication wires in the same conduit.
- Where power and serial communications wires must cross, the intersection should be perpendicular.
- All serial communication wires should be shielded. The shield should only be connected to ground at the Converter Box III.

Checking speaker volume

Before mounting the sign, check the volume setting of the speakers, as described in "Speaker volume control" on page 9.

Wall mounting instructions

Guidelines

Wall-mounting brackets are provided with the sign. Fasteners are supplied to attach the brackets *to the sign*. However, fasteners to attach the sign *to a wall* are not supplied.

The specific type of fastener needed depends on the physical characteristics of the wall (e.g., concrete, brick, wood) to which the sign is being mounted. Do NOT install directly to drywall, plasterboard, or other fragile supports.

- Fasteners for wall-mounting brackets must be appropriate for the type of wall to which the sign will be mounted.
- Each one of the fasteners must be capable of supporting four (4) times the weight of the sign.
- A sign must be attached to a wall (or to a wall-mounted support system) capable of supporting at least four (4) times the weight of the sign.

Directions

1. Disconnect power from the sign.
2. Remove the two screws from each end cap.

NOTE: There are speaker wires behind the right end cap, so be careful to keep one hand on the end cap — continuing to hold it in place — after removing the screws. Pull the end caps away slowly, so you don't accidentally snag the wiring or damage other components near the cap.

3. When the end caps have been removed, place each sliding bracket into the channel in the back of the sign. Use two (2) Keps fasteners to attach a mounting bracket to each sliding bracket. Tighten the Keps fasteners to 24 lb-in, 2.7 Nm:

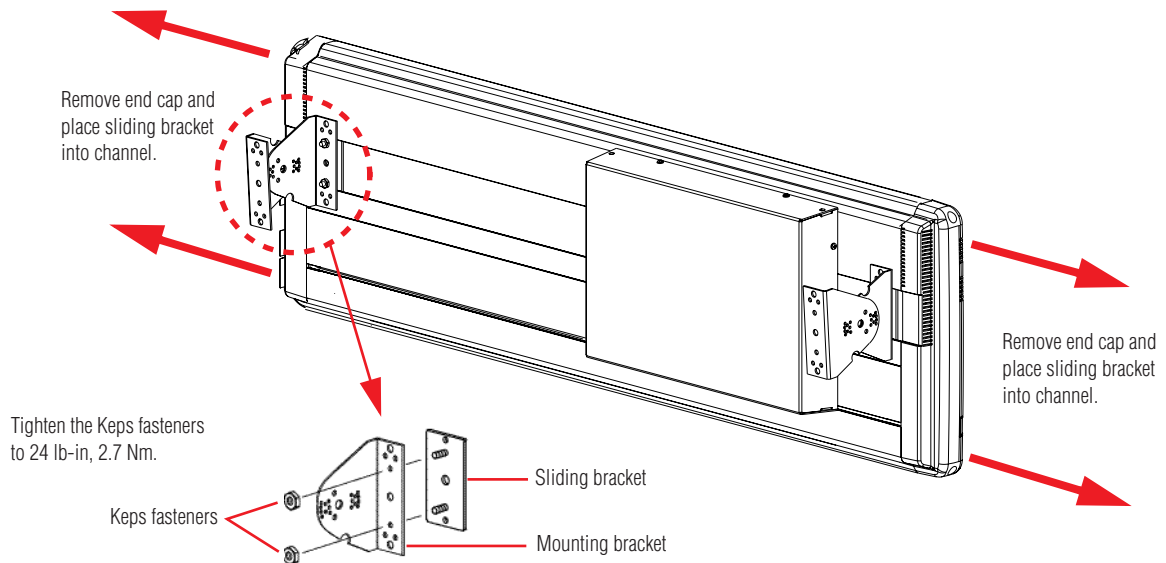

4. Attach the remaining two (2) mounting brackets to a wall.

NOTE: Do NOT install a sign directly to drywall or plasterboard or other fragile support.

NOTE: No fasteners are provided for the outer set of mounting brackets. The fasteners selected must be able to support four (4) times the weight of the sign.

5. Mount the sign on the wall. Use the supplied fasteners and cotter pins to attach the *sign* mounting brackets to the *wall* mounting brackets:

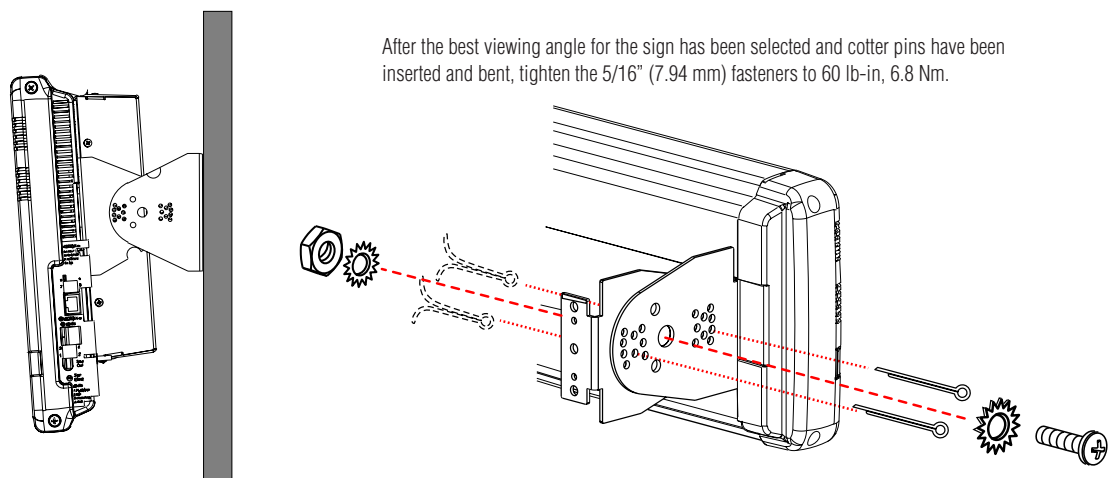

6. Replace the end caps. Be careful not to pinch any internal wires or catch other components between the lip of the end cap and the housing. Tighten end cap screws to 14 lb-in, 1.58 Nm.

Ceiling mounting instructions

Guidelines

A ceiling mounting bracket is provided with the sign. Fasteners to attach the sign to a ceiling are not supplied.

The specific type of fastener required will vary depending on the physical characteristics of the material (for example, concrete, brick, wood) to which the sign is being mounted. Do NOT install directly to drywall, plasterboard, or other fragile support.

- Fasteners for ceiling mounting brackets must be appropriate for the type of construction and material to which the sign will be mounted.
- Each of the fasteners must be capable of supporting four (4) times the weight of the sign.
- A sign must be attached to an overhead support capable of supporting four (4) times the weight of the sign.
- For adequate ventilation, allow at least 1 inch (2.54 cm) clearance all around the sign.

Directions

1. Disconnect power from the sign.
2. Remove the upper screw from each end cap. Slip the bottom of one hook support into the grooves between the tops of each end cap and the main housing:

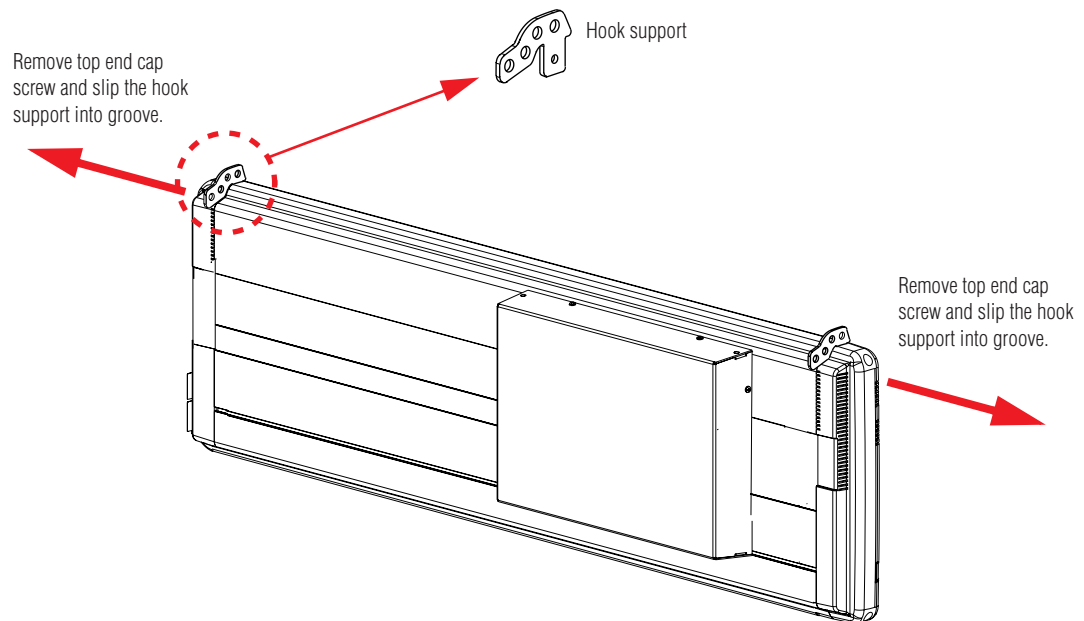

3. Replace each end cap screw. Make sure that the screw has gone through the hook support. Tighten screw to 14 lb-in, 1.58 Nm.
4. Mount ceiling attachments.
5. Attach hook supports to ceiling attachments. (Connection material not supplied.)

Counter mounting instructions

Guidelines

Counter mounting brackets are supplied with the sign. Fasteners to attach these mounting brackets to the sign are also supplied. However, fasteners to attach the mounting brackets to a counter are not supplied.

The specific type of fastener needed will vary depending on the physical characteristics of the counter (for example, concrete, brick, wood) to which the sign is being mounted. Do NOT install directly to drywall, plasterboard, or other fragile supports.

- Fasteners for counter mounting brackets must be appropriate for the type of counter to which the sign will be mounted.
- Each one of the fasteners must be capable of supporting four (4) times the weight of the sign.
- A sign must be attached to a counter capable of bearing at least four (4) times the weight of the sign.

Directions

1. Disconnect power from the sign.
2. Remove the two screws from each end cap.

NOTE: There are speaker wires behind the right end caps so be careful to keep one hand on the end cap — continuing to hold it in place — after removing the screws. Pull the end caps away slowly, so that you don't accidentally snag the wiring or damage other components behind the cap.

3. When the end caps have been removed, loosely fasten two screws in each mounting bracket as shown below, using the screws and nuts provided:

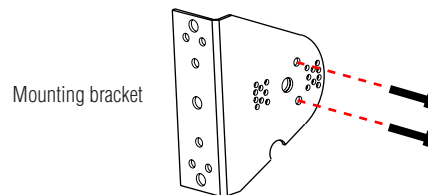

4. Next, slide the screw heads on each mounting bracket into the channel in the back of the sign. Then tighten the screws on each bracket:

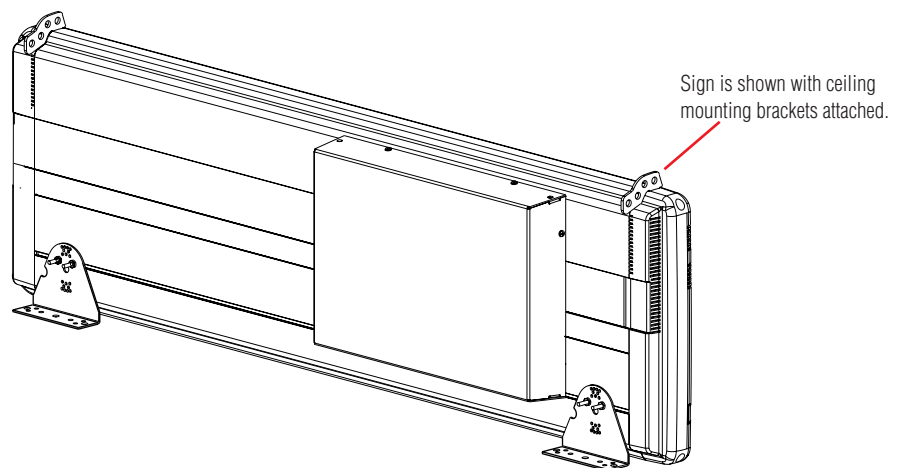

5. Replace the two screws in each end cap. Tighten each screw to 14 lb-in, 1.58 Nm.
6. Fasten each mounting bracket to the counter. (Connection material not supplied.)

Checkout procedure

After installing a sign according to the previous sections, make sure the unit is installed properly by applying power to it. Information *similar to the following* should be displayed on the sign:

Sign display	Meaning
1142-5001D 9000	Main firmware version
9000 SERIES 9240 COLOR	Sign type: in this case, an AlphaPremiere™ 9000 Series 9240 color sign.
CLEAR MEMORY	Only appears if the Memory clear DIP switch is on. See "Clearing memory" on page 11.
SERIAL ADDRESS 00 HEX	The serial address of the sign in hexadecimal.
SERIAL DATA 9600, 8n1	The baud rate (9600) and data format (8N1) for serial data communications.
RS485 ECHO DISABLED	See "RS485 echo (default = RS485 ECHO DISABLED)" on page 8.
INFRARED ENABLED	See "IR remote disable" under "Bank 1 and Bank 2 DIP switches" on page 7.
SPEAKER VOLUME [XXXX]	See "Speaker volume control" on page 9
PERF REV 211040001B v01.04	Peripheral firmware version.
FPGA REV 26111401 V1.4	FPGA chip version.
RAM 1 RAM 512K	Amount of internal sign memory.
10:48 AM FRI. FEB. 23, 2003	Current date.
DEMO MSG: ON	See "Demonstration messages" under "Bank 1 and Bank 2 DIP switches" on page 7.
CHECKING FLASH LO CKS XXXX HI CKS XXXX	Self-test of the sign's FLASH memory. FLASH OK should appear after the checksums (LO CKS and HI CKS).
NO COBOX	If the sign has no internal Ethernet card, then NO COBOX will appear. If the sign has an internal Ethernet card, then the sign's IP address will appear.

Service and maintenance

Firmware updates

The internal program or firmware (also referred to as "flash EPROM") that runs an AlphaPremiere™ 9000 sign may need to be updated from time to time.

To find out the availability of any updates, see the following web page: <http://www.adaptivedisplays.com/support.htm>.

Routine cleaning

When cleaning the case, use a soft lint-free cotton cloth with mild soap and water. Alcohol and cleaners with alcohol (or any other strong solvent) are not recommended.

If the front lens becomes dusty, use a vacuum cleaner that has a soft brush on an extension wand.