

## Contents

<b>Introduction</b> . . . . .	<b>1</b>
Purpose . . . . .	1
Revision history . . . . .	1
Related documentation . . . . .	1
Safety information . . . . .	2
Controlling electrostatic discharge . . . . .	3
<b>Equipment overview</b> . . . . .	<b>4</b>
Description . . . . .	5
Equipment identification . . . . .	7
EMI compliance . . . . .	7
Power reduction . . . . .	7
<b>Networking signs</b> . . . . .	<b>8</b>
Ethernet network example . . . . .	8
RS485 network example . . . . .	8
RS485/Ethernet network example . . . . .	9
Modular Network Adapter wiring . . . . .	9
Ethernet option wiring . . . . .	10
<b>Installation</b> . . . . .	<b>11</b>
Mechanical installation . . . . .	11
Electrical installation . . . . .	15
<b>Appendix</b> . . . . .	<b>16</b>
Appendix A: Controller board settings . . . . .	16
Appendix B: Opening a sign . . . . .	23
Appendix C: Multi-section sign wiring . . . . .	25
Appendix D: Technical specifications . . . . .	26

## Introduction

AlphaVision™ InfoTracker LED signs can display real-time market data, proprietary information, news headlines, and text messages.

Depending on its size, a sign will be cased either in a single cabinet or in multiple sections.

All sign models are front serviceable. However, there are no customer serviceable parts inside a sign.

## Purpose

These instructions are intended as a guide for the installation and setup of AlphaVision™ InfoTracker LED signs with either 1.4- or 2.1-inch character heights.

## Revision history

Part number	Date	Notes
9711-2202	July 24, 2000	First release
9711-2202A	June 3, 2002	Information on the internal Ethernet option was added in this revision.
9711-2202B	June 9, 2003	<ul style="list-style-type: none"> <li>• DIP switch X-coordinate information corrected</li> <li>• sign opening procedure corrected.</li> <li>• RS485 network wiring changed</li> <li>• document format changed</li> </ul>

## Related documentation

Part number	Title	Notes
9708-8061	Alpha® Sign Communications Protocol	A programmer's reference guide for communicating with an Alpha® sign using its native protocol language.

Safety information

Equipment symbols



Chassis ground

Warnings and cautions

	<b>⚠ WARNING</b>
	<p><b>Hazardous voltage.</b>                  Contact with high voltage may cause death or serious injury.                  Always disconnect power to unit prior to servicing. <small>SM1000A</small></p>

	<b>⚠ WARNING</b>
	<p><b>Possible fire hazard.</b>                  Always mount unit indoors. Mounting the unit outdoors may cause a fire which could result in serious injury or death. <small>SM1007A</small></p>

	<b>⚠ WARNING</b>
	<p><b>Possible shock hazard.</b>                  Always mount unit indoors. Mounting a unit outdoors makes the unit a possible source of electric shock which could result in serious injury or death. <small>SM1001A</small></p>

	<b>⚠ WARNING</b>
	<p><b>Possible crush hazard.</b>                  Mount unit on a wall that can support at least 4 times the unit's weight. Otherwise unit may fall causing serious injury or death. <small>SM1003A</small></p>

Electrical protection devices

English

A readily-accessible disconnect device shall be installed in the fixed wiring supplying power to this equipment. The disconnect device shall have a contact separation of at least 3 mm.

This equipment relies on protective devices in the building installation for protection for short circuit and/or overcurrent protection. Install this equipment only where these protective devices are present. The size and type of the protective devices shall be appropriate for the voltage and current ratings on this equipment.

Français

Un dispositif de déconnexion placé à un endroit pratique doit être installé sur le fil fixe qui alimente ce matériel. La distance des contacts de ce dispositif de déconnexion doit être de 3 mm minimum.

Ce matériel s'appuie sur des dispositifs de protection dans l'installation du bâtiment pour se protéger des courts-circuits et/ou des surintensités. Installez ce matériel seulement là où de telles protections sont présentes. Le calibre et le type des protections doivent être adaptés à la tension et à l'intensité nominales du matériel.

Deutsch

In der Festverdrahtung muß eine leicht zugängliche Trennvorrichtung installiert werden, die dieses Gerät mit Strom versorgt. Die Trennvorrichtung muß eine Kontakttrennung von mindestens 3 mm aufweisen.

Kurzschlußschutz und/oder Überstromschutz wird in diesem Gerät durch entsprechende Schutzvorrichtungen in der Gebäudeinstallation gewährleistet. Dieses Gerät nur dort installieren, wo diese Schutzvorrichtungen vorhanden sind. Größe und Art der Schutzvorrichtungen müssen den Spannungs- und Stromnennstärken dieses Geräts entsprechen.

### Italiano

Un dispositivo di sconnessione prontamente accessibile dovrà essere installato nel cablaggio fissato che fornisce corrente alla presente apparecchiatura. Il dispositivo di sconnessione dovrà avere una separazione di contatto di almeno 3 mm.

La presente apparecchiatura si affida a dispositivi di protezione nell'installazione da edificio per protezione da corto circuito e/o protezione da sovracorrente. Installare l'apparecchiatura solamente in punti dove sono presenti questi dispositivi di protezione. Le dimensioni e il tipo di dispositivo di protezione dovranno essere appropriati alla tensione e ai valori di corrente della presente apparecchiatura.

### Español

Se debe instalar en el cableado fijo que alimenta este equipo un dispositivo de desconexión fácilmente accesible. Dicho dispositivo tendrá una separación entre contactos de por lo menos 3 mm.

Este equipo depende del uso de dispositivos protectores en la instalación del edificio para protección en caso de cortocircuito y/o protección contra sobretensión. Instale este equipo únicamente en caso de disponer de dispositivos protectores. El tipo y tamaño de los dispositivos protectores deberán ser adecuados para los valores nominales de tensión y corriente de este equipo.

### Controlling electrostatic discharge

---



Adaptive Micro System signs contain components that may be damaged by electrostatic discharge (static electricity). Follow the guidelines in Adaptive Tech Memo 00-0005, **Preventing Electrostatic Discharge (ESD) Damage**, available on Adaptive's web site: <http://www.adaptivedisplays.com>.

---

## Equipment overview

---

AlphaVision™ InfoTracker LED signs can display real-time market data, proprietary information, news headlines, and messaging.

Depending on its size, a sign will be cased in either a single cabinet or in multiple sections.

Signs are mounted by fastening two mounting bars to a wall and then hanging the sign on these bars.

Messages can be sent to a sign via an Ethernet or a serial RS485 connection.

**Description**

**Outside view**

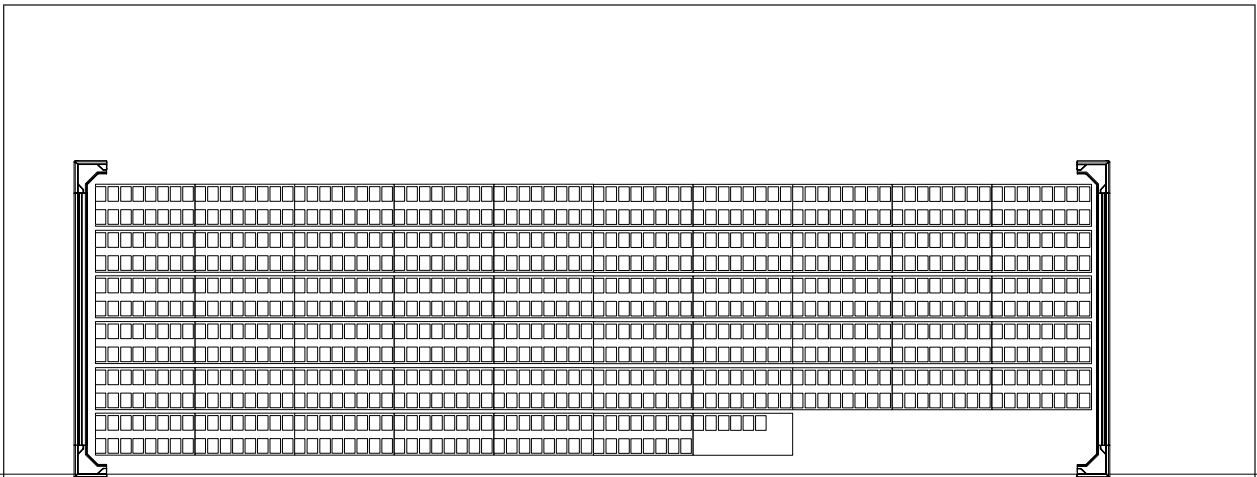

Left section  
(40 characters)

Right section  
(40 characters)

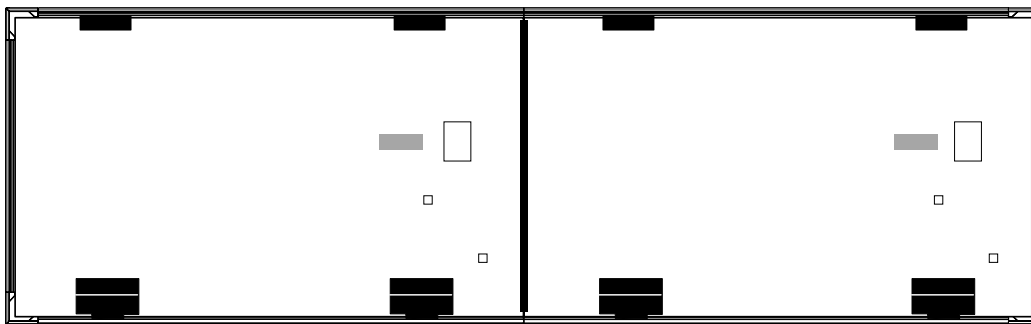

Item	Name	Description
A	Top mounting bracket (pn 6811-2401)	Used to hang the section on the wall mounting bar.
B	Equipment identification label	See "Equipment identification" on page 7.

<b>C</b>	Power cord jack	Carries electrical power to the sign. The location of this jack varies with the size of the sign and each section may <u>not</u> have a jack.
<b>D</b>	Ethernet jack	(Optional) Provides an Ethernet (10BASE-T) data connection. The location of this jack varies with the size of the sign and each section may <u>not</u> have a jack.
<b>E</b>	MAC ADDRESS label (underneath Ethernet jack)	(Only with Ethernet option) Identifies the MAC address of the Ethernet card inside the sign. The MAC address is used to set a sign's IP address. 
<b>F</b>	RS485 jack	Provides a serial (RS485) data connection. The location of this jack varies with the size of the sign and each section may <u>not</u> have a jack.
<b>G</b>	Bottom mounting bracket (pn 6811-2411)	Used to hang the section on the wall mounting bar.  NOTE: Bottom mounting brackets (item G) are only necessary if the sign is (1) hung at an angle or (2) mounted in an area prone to earthquakes.
<b>H</b>	H-channel bracket	Used to connect the back panels of two, adjacent signs.

**Inside view**

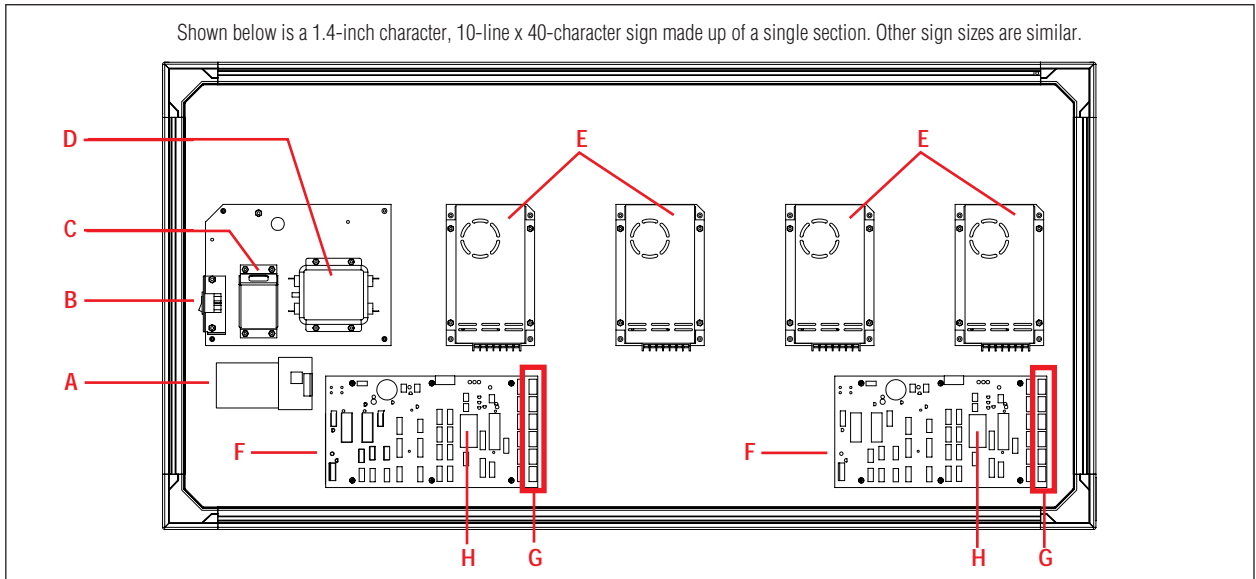

Item	Name	Description
<b>A</b>	Ethernet card	(Optional) Provides an Ethernet (10BASE-T) data connection.
<b>B</b>	Power switch	Used to disconnect power from the sign.
<b>C</b>	Incoming power terminal	Unfiltered line voltage.
<b>D</b>	EMI filter	Provides filtered power to sign sections.
<b>E</b>	Power supply	Provides power to the LED and the controller boards.
<b>F</b>	Controller board	Contains the firmware EPROM. Data is then sent to the LED boards from each controller board which can support up to 256 characters (or 16 LED boards).
<b>G</b>	DIP switches	See "Appendix A: Controller board" on page 16.
<b>H</b>	Firmware EPROM	Each controller board contains a firmware EPROM chip. This chip contains the instructions that operate the sign. From time to time a sign's firmware may be updated to correct problems or to add new features. Each firmware EPROM chip is labelled with the version of firmware it contains as the example below shows:    The firmware version of this EPROM is "1.2.0". ("1122-6001" is the part number of this EPROM chip.)  The EPROM chip can be removed from its socket with a small screwdriver.

**Equipment identification**

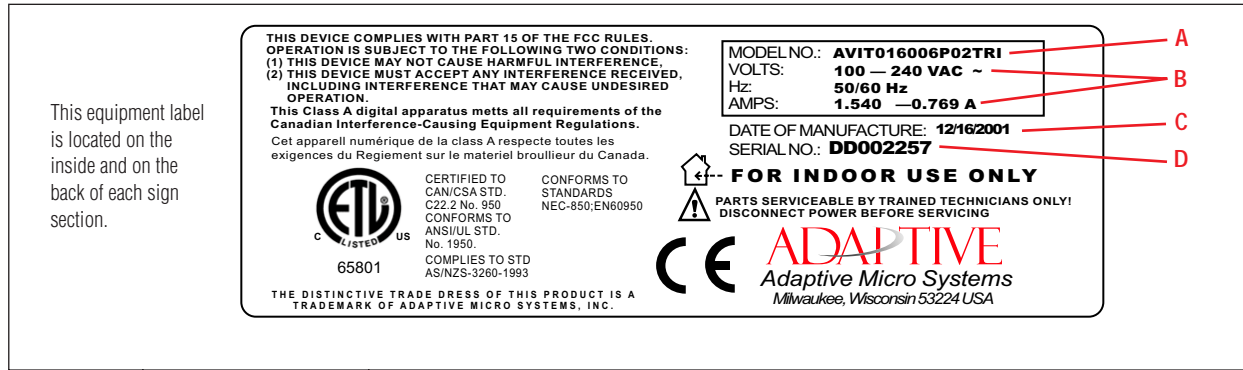

Item	Name	Description
A	Model number	<p><b>AVIT016006P02TRI</b></p> <ul style="list-style-type: none"> <li><b>LED color:</b> TRI = tri-color</li> <li><b>Pitch (distance between each LED):</b> P02 = 0.2-inch pitch (1.4-inch characters) or P03 = 0.3-inch pitch (2.1-inch characters)</li> <li><b>Display height in rows</b> from 6 to 32 in increments of 2</li> <li><b>Number characters in each line or row:</b> from 16 to 96 in increments of 8</li> <li><b>Model:</b> AlphaVision™ InfoTracker sign</li> </ul>
B	Electrical information	Input voltage, frequency, amperage per circuit.
C	Date of manufacture	Month, day, and year the sign was made.
D	Serial number	Consecutive, unique identification number.

**EMI compliance**

This equipment has been tested and found to comply with the limits for a Class A digital device, pursuant to Part 15 of the FCC Rules. These limits are designed to provide reasonable protection against harmful interference when the equipment is operated in a commercial environment.

This equipment generates, uses, and can radiate radio frequency energy and, if not installed and used in accordance with installation guidelines, may cause harmful interference to radio communications. Operation of this equipment in a residential area is likely to cause harmful interference, in which case the user will be required to correct the interference at his own expense.

**Power reduction**

If the display load exceeds 57% of maximum display load, then the user is responsible for reducing brightness through the software in order to prevent overloading the power supply.

## Networking signs

AlphaVision™ InfoTracker signs can be connected to a computer using either:

- RS485 or
- 10BASE-T Ethernet

### Ethernet network example

In this example, one or more signs are connected to a computer using an Ethernet LAN. Each sign in this example would need an internal Ethernet adapter installed.

Each sign in this example would be able to display the same data *or* different data.

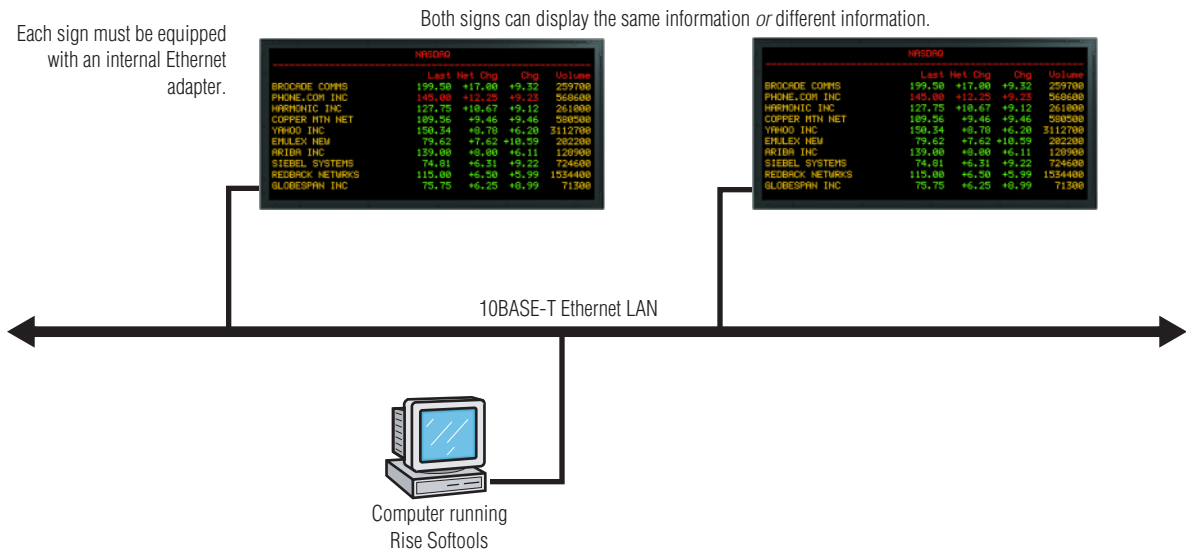

Figure 1: Connecting AlphaVision™ InfoTracker signs to an Ethernet LAN

### RS485 network example

In this example, one or more signs are connected to a computer using a RS485 network.

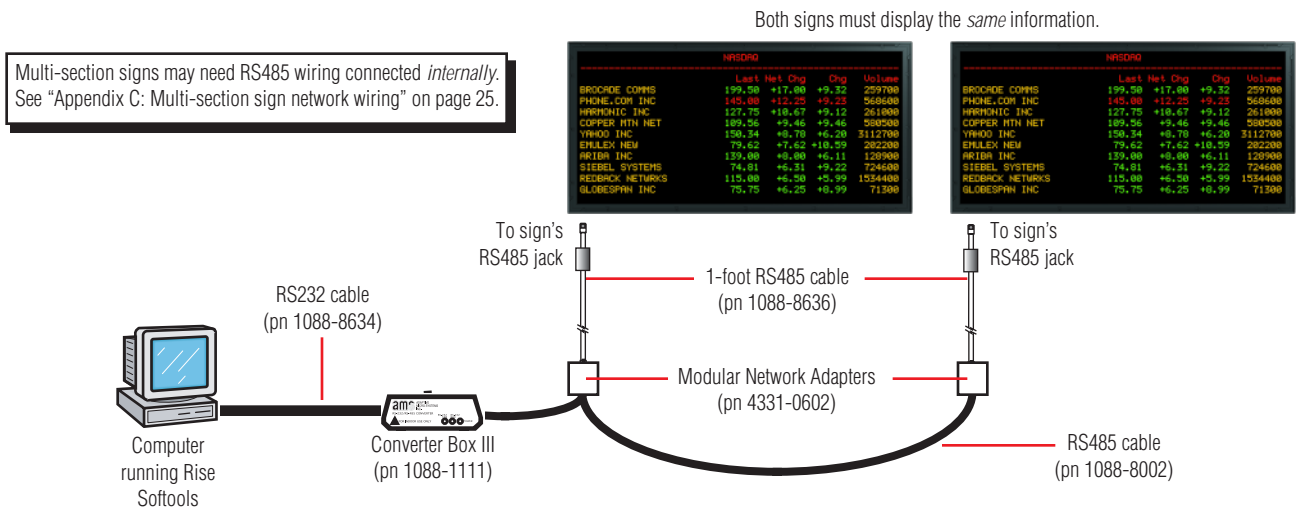

Figure 2: Connecting Rise Tracker™ signs using a RS485 network



RS485/Ethernet network example

Multi-section signs may need RS485 wiring connected *internally*. See "Appendix C: Multi-section sign network wiring" on page 25.

Both signs must display the *same* information.

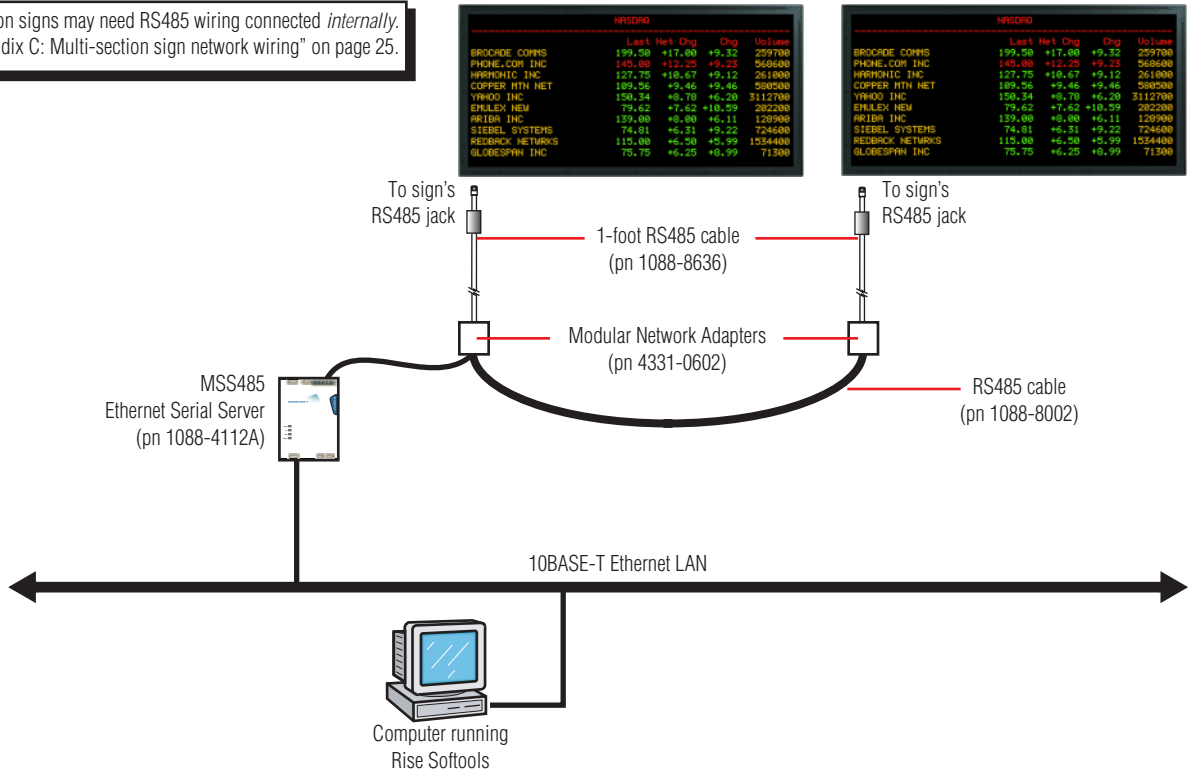
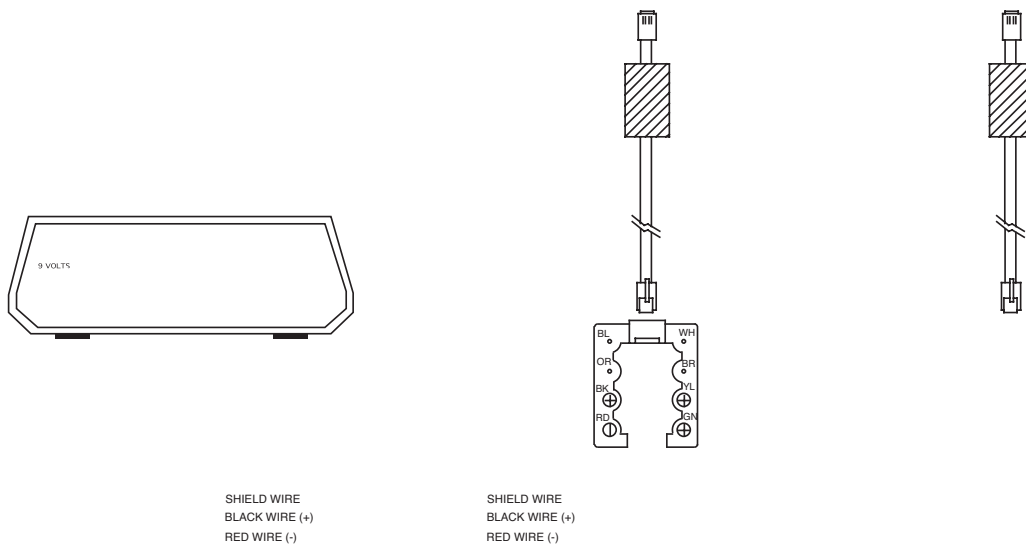

Figure 3: Connecting AlphaVision™ InfoTracker signs using a RS485/Ethernet network

Modular Network Adapter wiring

When connecting multiple signs using a RS485 network, Modular Network Adapters are needed and are wired as shown below:



### Ethernet option wiring

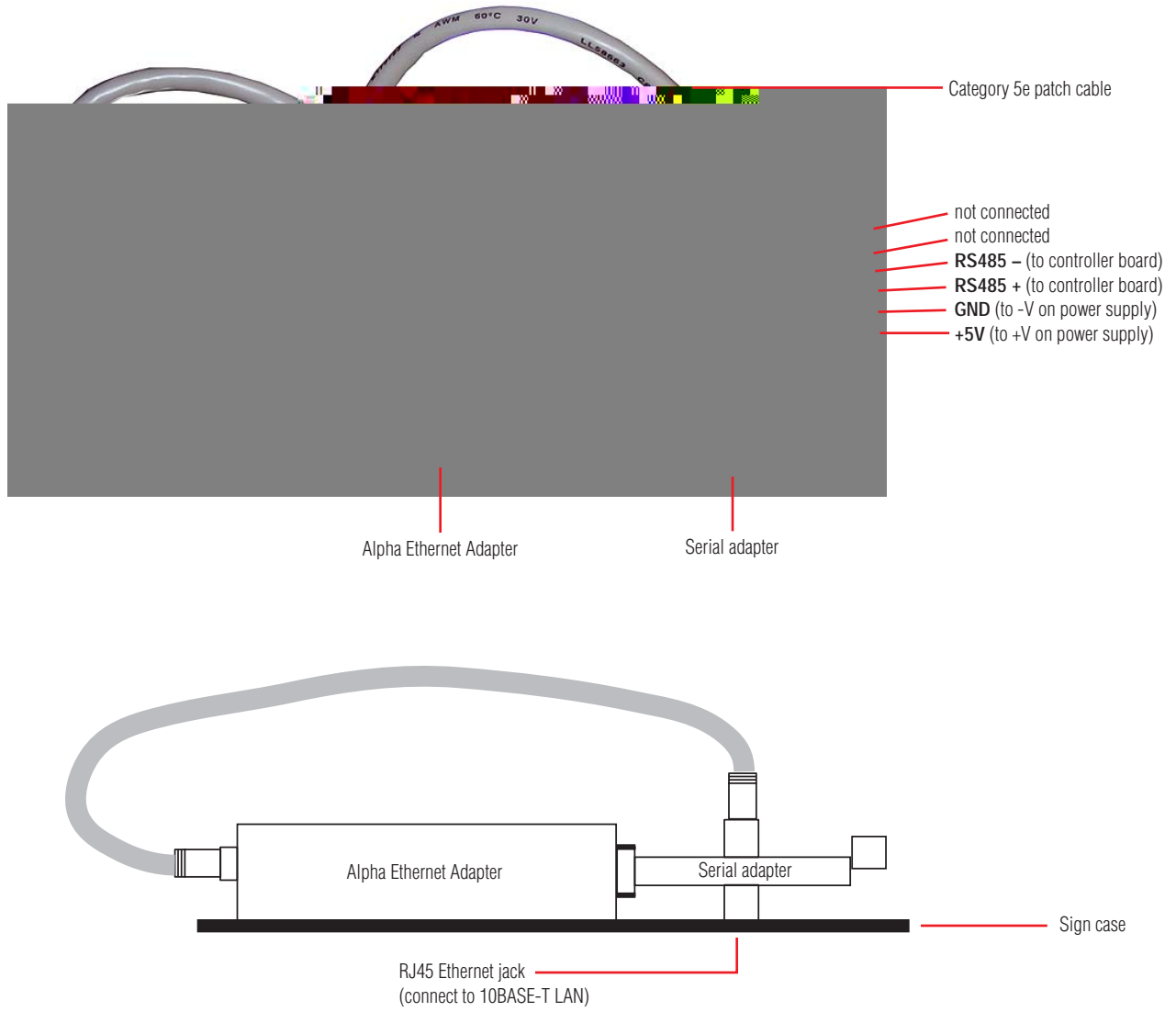

Figure 5: Ethernet option wiring

---

## Installation

---

### Mechanical installation

---

#### Design of the support structure

1. For each sign section, attach at least 3 top mounting brackets (pn 6811-2401) and 2 bottom mounting brackets (pn 6811-2411, not shown) using the supplied hardware as shown below:

*Side view of sign section*

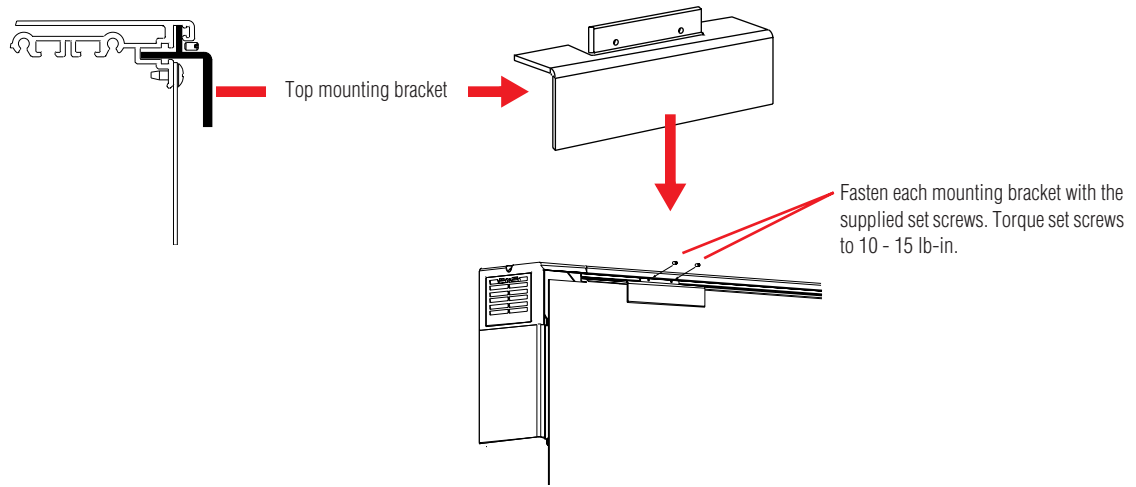

Figure 6: Top and bottom sign mounting bracket attachment

2. For each sign section, attach an upper and a lower section connection plate using the supplied hardware. These plates hold the sections together:

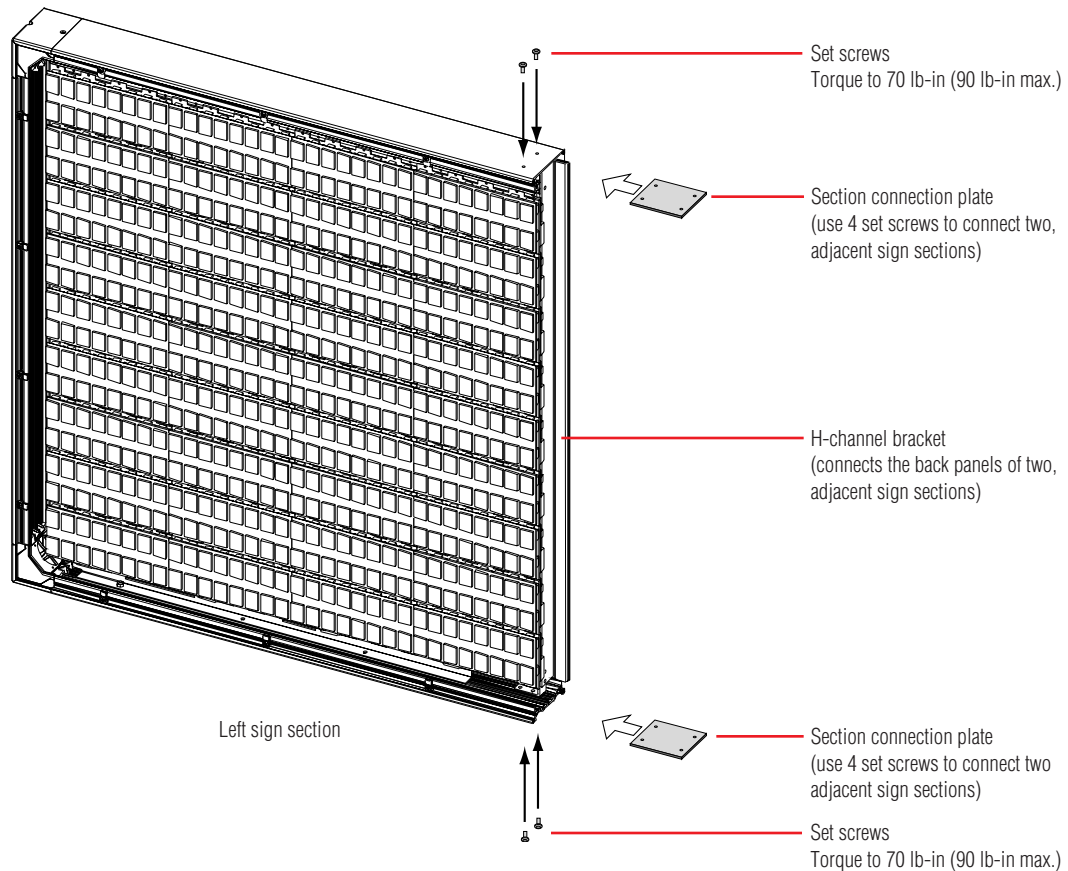

Figure 7: Section connection plate attachment

3. Attach the upper and lower wall mounting bar(s) (pn 6802-0004) to the wall where the sign will be hung.

**NOTE:** The support structure and mounting hardware must be capable of safely supporting four (4) times the weight of the sign.

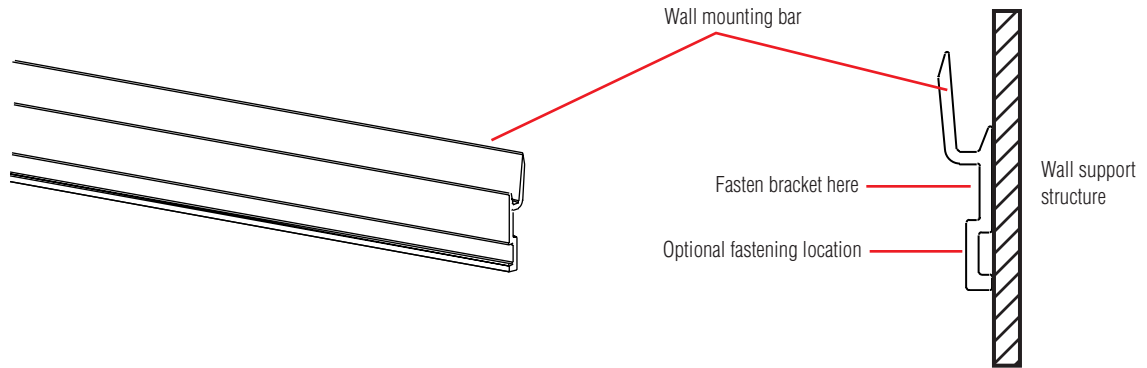
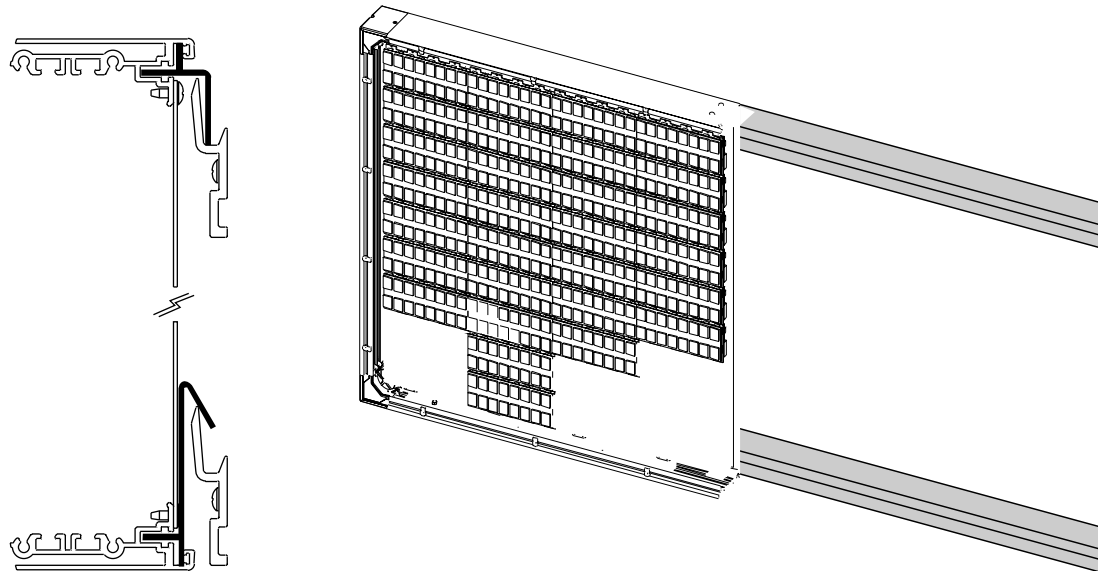

Figure 8: Wall mounting bar attachment

4. Using at least 2 people, lift each sign section so the section hangs from the top and bottom sign mounting brackets:



5. If a sign section will have power run to it, connect a power conduit to this section *before* attaching this section to any other sign sections. This allows you to make adjustments without having to disassemble the entire sign. However, power wiring should only be connected to a power source after all the sign sections have been mounted.

6. Before connecting two sign sections, make sure the H-channel bracket is ready as shown below:

**STEP 1:**  
Place EMI gaskets on the sign section back panels.

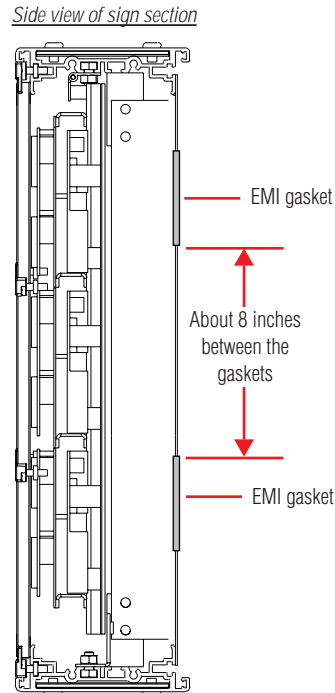

**STEP 2:**  
Put the H-channel bracket over the gaskets.

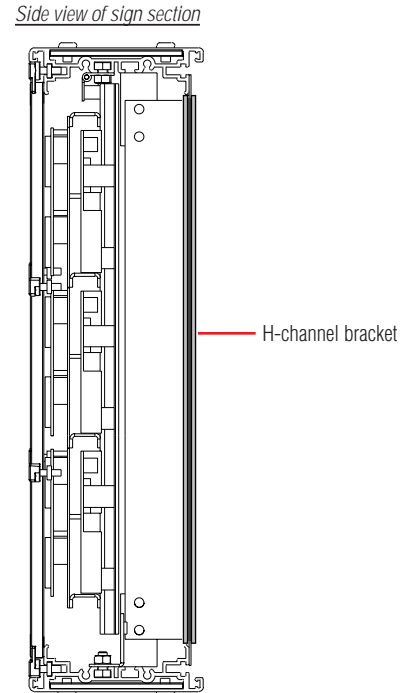

**STEP 3:**  
Use the H-channel bracket to connect the back panels.

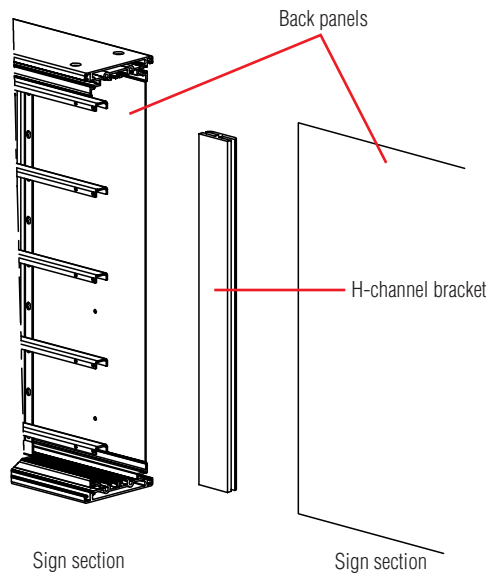

Figure 10: H-channel bracket preparation

## Electrical installation

---

**NOTE:** Electrical installation should only be attempted by qualified personnel. Electrical connection must comply with all applicable national and local codes.

- Signs may have multiple power entries and all power sources must be removed prior to servicing.
- Each power entry should be connected to its own branch circuit.
- Each circuit should be protected by up to a 20-amp circuit breaker.
- Before power is applied, the installer must verify ground continuity between the sign's metal case and the building's earth ground system.
- Electrical protection devices for signs must include the following:
  - A readily-accessible disconnect device should be installed in the fixed wiring supplying power to this equipment.
  - This equipment relies on devices in the building installation for short circuit and overcurrent protection. Install this equipment only where these protective devices are present. The size and type of the protective devices shall be appropriate for the voltage and current ratings on this equipment.

## Appendix

### Appendix A: Controller board

#### Description

The controller board receives sign messages from either an RS485 or Ethernet connection to a computer. The controller board processes these messages and displays them on the sign.

DIP switches and jumpers on the controller board determine sign operation.

A sign (or a section of a sign) will contain one or more controller boards.

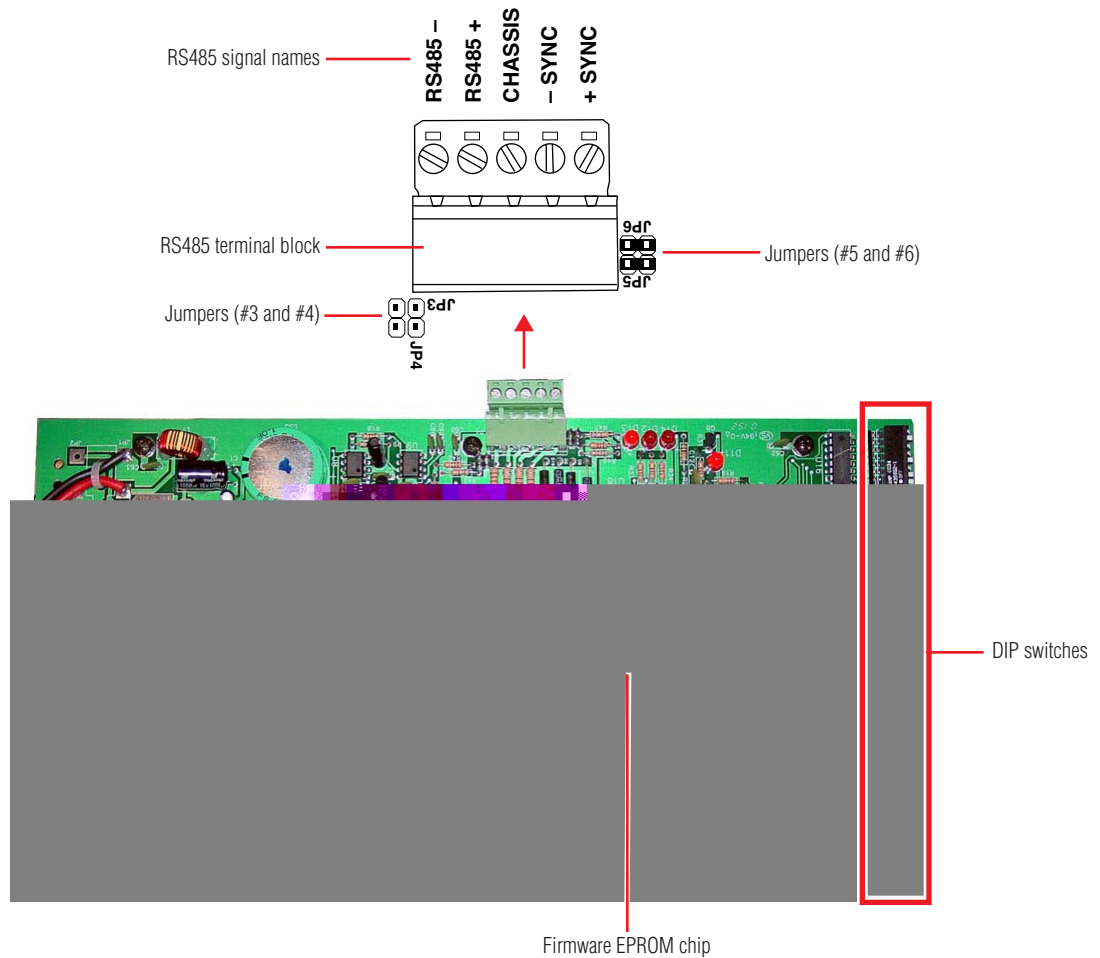

Figure 11: Controller board

#### Terminology

- **Section** — a sign may be made up of one or more sections. For example, a sign could be made up of a left and a right section; or a left, a center, and a right section; or a left section, multiple center sections, and a right section.
- **Division** — a group of LED driver boards in a sign that is controlled by only one controller board.



- **Panel** — a combination of two or more Divisions. A Panel can be up to 96 characters. Panels can be set up to display different types of information. For example, you could display one message in one part of the sign and a second message in another part.
- **Brightness area** — a part of a panel that acts as a unique area for software message commands for flashing or setting the level of brightness. A brightness area cannot span more than one panel.

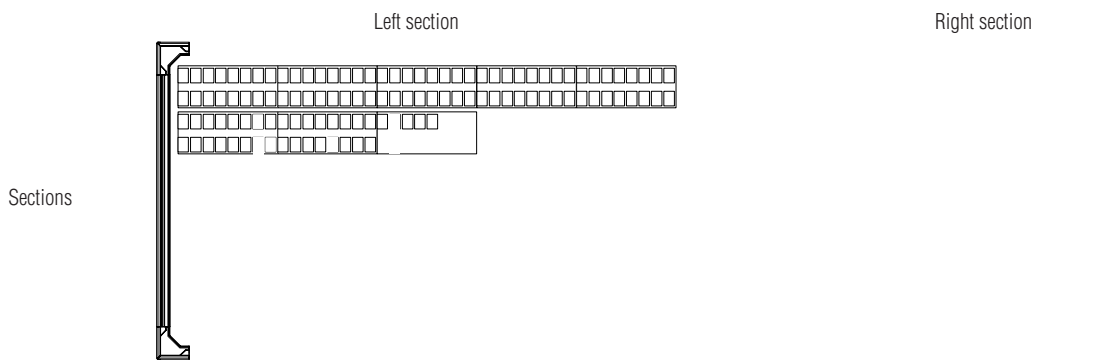
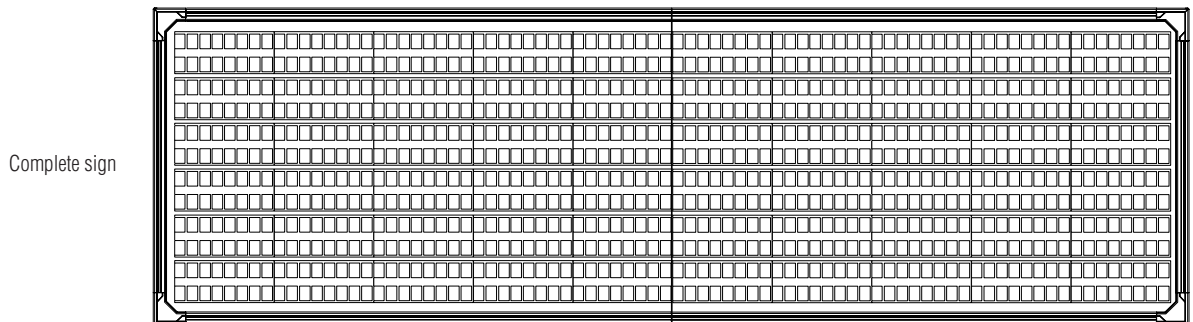

Divisions and panels  
(some divisions are  
grayed out to make it  
easier to see them)

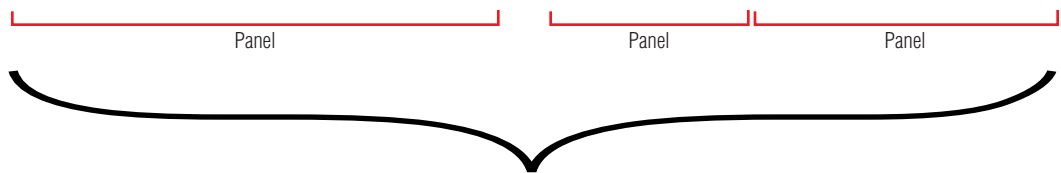

Figure 12: Sign section, division, and panel example

**DIP switch settings**

Side view: SW1 SW2 SW3 SW4 SW5 SW6

Panel address: Use panel address?

Brightness area address: Brightness area address

Division height (rows): Division height (rows)

Division width (characters): Division width (characters)

Diagnostic mode: Diagnostic mode

Division Y coordinate: Division Y coordinate

Master/Slave mode: Master/Slave mode

Division X coordinate: Division X coordinate

Baud rate: Baud rate

Sign type: Data format

unused

SW1	<b>1</b> Use panel address?									
	OFF	Do NOT use panel address. The panel will display all messages.								
	ON	Use panel address. The panel will only display messages sent to the panel address. (Factory setting)								
	<b>MSB</b>	<b>2</b>	<b>3</b>	<b>4</b>	<b>5</b>	<b>6</b>	<b>7</b>	<b>LSB</b>	<b>8</b>	<b>Panel address (1 to 95)</b>
	OFF	OFF	OFF	OFF	OFF	OFF	OFF	OFF	OFF	= Factory setting
	OFF	OFF	OFF	OFF	OFF	OFF	OFF	ON	OFF	= Panel address 1
OFF	OFF	OFF	OFF	OFF	ON	OFF	OFF	OFF	= Panel address 2	
.	.	.	.	.	.	.	.	.		
ON	OFF	ON	ON	ON	ON	ON	ON	ON	= Panel address 95	

SW2 & SW3	<b>MSB</b>	<b>1</b>	<b>2</b>	<b>3</b>	<b>LSB</b>	<b>4</b>	<b>Brightness area address (from 80 to 95)</b>			
	OFF	OFF	OFF	OFF	OFF	OFF	= Section address 80 (Factory setting)			
	OFF	OFF	OFF	OFF	ON	OFF	= Section address 81			
	OFF	OFF	ON	OFF	OFF	OFF	= Section address 82			
	.	.	.	.	.	.				
	ON	ON	ON	ON	ON	ON	= Section address 95			

SW3	<b>SW2</b>				<b>SW3</b>	<b>Division height (rows) (from 1 to 31)</b>				
	<b>MSB</b>	<b>5</b>	<b>6</b>	<b>7</b>	<b>8</b>	<b>LSB</b>	<b>1</b>			
	OFF	OFF	OFF	OFF	OFF	OFF	OFF	= not a valid value		
	OFF	OFF	OFF	OFF	OFF	ON	OFF	= Division height 1 row		
	OFF	OFF	OFF	ON	OFF	OFF	OFF	= Division height 2 rows		
	.	.	.	.	.	.	.			
ON	ON	ON	ON	ON	ON	ON	= Division height 31 rows			

SW3	<b>MSB</b>	<b>2</b>	<b>3</b>	<b>4</b>	<b>5</b>	<b>6</b>	<b>7</b>	<b>LSB</b>	<b>8</b>	<b>Division width (characters) (1 to 95)</b>
	OFF	OFF	OFF	OFF	OFF	OFF	OFF	OFF	OFF	= not a valid value
	OFF	OFF	OFF	OFF	OFF	OFF	OFF	ON	OFF	= Division width 1 character
	OFF	OFF	OFF	OFF	OFF	ON	OFF	OFF	OFF	= Division width 2 characters
	.	.	.	.	.	.	.	.	.	
	ON	OFF	ON	ON	ON	ON	ON	ON	ON	= Division width 95 characters

SW4	<table border="1"> <tr> <td><b>1</b></td> <td colspan="7"><b>Diagnostic mode</b></td> </tr> <tr> <td>OFF</td> <td colspan="7">Normal operating mode</td> </tr> <tr> <td>ON</td> <td colspan="7">Diagnostic mode (used for factory testing)</td> </tr> </table>								<b>1</b>	<b>Diagnostic mode</b>							OFF	Normal operating mode							ON	Diagnostic mode (used for factory testing)																																																						
	<b>1</b>	<b>Diagnostic mode</b>																																																																														
	OFF	Normal operating mode																																																																														
	ON	Diagnostic mode (used for factory testing)																																																																														
	<table border="1"> <tr> <td><b>MSB</b> <b>2</b></td> <td><b>3</b></td> <td><b>4</b></td> <td><b>5</b></td> <td><b>6</b></td> <td><b>7</b></td> <td><b>LSB</b> <b>8</b></td> <td><b>Division Y coordinate (1 to 95)</b> <b>(the Y coordinate of the upper left-hand corner of the division)</b></td> </tr> <tr> <td>OFF</td> <td>OFF</td> <td>OFF</td> <td>OFF</td> <td>OFF</td> <td>OFF</td> <td>OFF</td> <td>= not a valid value</td> </tr> <tr> <td>OFF</td> <td>OFF</td> <td>OFF</td> <td>OFF</td> <td>OFF</td> <td>OFF</td> <td>ON</td> <td>= Division Y coordinate 1</td> </tr> <tr> <td>OFF</td> <td>OFF</td> <td>OFF</td> <td>OFF</td> <td>OFF</td> <td>ON</td> <td>OFF</td> <td>= Division Y coordinate 2</td> </tr> <tr> <td>.</td> <td>.</td> <td>.</td> <td>.</td> <td>.</td> <td>.</td> <td>.</td> <td></td> </tr> <tr> <td>ON</td> <td>OFF</td> <td>ON</td> <td>ON</td> <td>ON</td> <td>ON</td> <td>ON</td> <td>= Division Y coordinate 95</td> </tr> </table>								<b>MSB</b> <b>2</b>	<b>3</b>	<b>4</b>	<b>5</b>	<b>6</b>	<b>7</b>	<b>LSB</b> <b>8</b>	<b>Division Y coordinate (1 to 95)</b> <b>(the Y coordinate of the upper left-hand corner of the division)</b>	OFF	OFF	OFF	OFF	OFF	OFF	OFF	= not a valid value	OFF	OFF	OFF	OFF	OFF	OFF	ON	= Division Y coordinate 1	OFF	OFF	OFF	OFF	OFF	ON	OFF	= Division Y coordinate 2	.	.	.	.	.	.	.		ON	OFF	ON	ON	ON	ON	ON	= Division Y coordinate 95																								
	<b>MSB</b> <b>2</b>	<b>3</b>	<b>4</b>	<b>5</b>	<b>6</b>	<b>7</b>	<b>LSB</b> <b>8</b>	<b>Division Y coordinate (1 to 95)</b> <b>(the Y coordinate of the upper left-hand corner of the division)</b>																																																																								
	OFF	OFF	OFF	OFF	OFF	OFF	OFF	= not a valid value																																																																								
	OFF	OFF	OFF	OFF	OFF	OFF	ON	= Division Y coordinate 1																																																																								
	OFF	OFF	OFF	OFF	OFF	ON	OFF	= Division Y coordinate 2																																																																								
	.	.	.	.	.	.	.																																																																									
ON	OFF	ON	ON	ON	ON	ON	= Division Y coordinate 95																																																																									
SW5	<table border="1"> <tr> <td><b>1</b></td> <td colspan="7"><b>Master/Slave mode</b> <b>(a panel property)</b></td> </tr> <tr> <td>OFF</td> <td colspan="7">Slave mode</td> </tr> <tr> <td>ON</td> <td colspan="7">Master mode (Only one controller should operate in this mode.)</td> </tr> </table>								<b>1</b>	<b>Master/Slave mode</b> <b>(a panel property)</b>							OFF	Slave mode							ON	Master mode (Only one controller should operate in this mode.)																																																						
	<b>1</b>	<b>Master/Slave mode</b> <b>(a panel property)</b>																																																																														
	OFF	Slave mode																																																																														
	ON	Master mode (Only one controller should operate in this mode.)																																																																														
	<table border="1"> <tr> <td><b>MSB</b> <b>2</b></td> <td><b>3</b></td> <td><b>4</b></td> <td><b>5</b></td> <td><b>6</b></td> <td><b>7</b></td> <td><b>LSB</b> <b>8</b></td> <td><b>Division X coordinate (1 to 95)</b> <b>(the X coordinate of the upper left-hand corner of the division)</b></td> </tr> <tr> <td>OFF</td> <td>OFF</td> <td>OFF</td> <td>OFF</td> <td>OFF</td> <td>OFF</td> <td>OFF</td> <td>= not a valid value</td> </tr> <tr> <td>OFF</td> <td>OFF</td> <td>OFF</td> <td>OFF</td> <td>OFF</td> <td>OFF</td> <td>ON</td> <td>= Division Y coordinate 1</td> </tr> <tr> <td>OFF</td> <td>OFF</td> <td>OFF</td> <td>OFF</td> <td>OFF</td> <td>ON</td> <td>OFF</td> <td>= Division Y coordinate 2</td> </tr> <tr> <td>.</td> <td>.</td> <td>.</td> <td>.</td> <td>.</td> <td>.</td> <td>.</td> <td></td> </tr> <tr> <td>ON</td> <td>OFF</td> <td>ON</td> <td>ON</td> <td>ON</td> <td>ON</td> <td>ON</td> <td>= Division Y coordinate 95</td> </tr> </table>								<b>MSB</b> <b>2</b>	<b>3</b>	<b>4</b>	<b>5</b>	<b>6</b>	<b>7</b>	<b>LSB</b> <b>8</b>	<b>Division X coordinate (1 to 95)</b> <b>(the X coordinate of the upper left-hand corner of the division)</b>	OFF	OFF	OFF	OFF	OFF	OFF	OFF	= not a valid value	OFF	OFF	OFF	OFF	OFF	OFF	ON	= Division Y coordinate 1	OFF	OFF	OFF	OFF	OFF	ON	OFF	= Division Y coordinate 2	.	.	.	.	.	.	.		ON	OFF	ON	ON	ON	ON	ON	= Division Y coordinate 95																								
	<b>MSB</b> <b>2</b>	<b>3</b>	<b>4</b>	<b>5</b>	<b>6</b>	<b>7</b>	<b>LSB</b> <b>8</b>	<b>Division X coordinate (1 to 95)</b> <b>(the X coordinate of the upper left-hand corner of the division)</b>																																																																								
	OFF	OFF	OFF	OFF	OFF	OFF	OFF	= not a valid value																																																																								
	OFF	OFF	OFF	OFF	OFF	OFF	ON	= Division Y coordinate 1																																																																								
	OFF	OFF	OFF	OFF	OFF	ON	OFF	= Division Y coordinate 2																																																																								
	.	.	.	.	.	.	.																																																																									
ON	OFF	ON	ON	ON	ON	ON	= Division Y coordinate 95																																																																									
SW6	<table border="1"> <tr> <td><b>3</b></td> <td><b>4</b></td> <td><b>5</b></td> <td colspan="5"><b>Baud rate</b> <b>(all divisions should be set to the same baud rate)</b></td> </tr> <tr> <td>OFF</td> <td>OFF</td> <td>OFF</td> <td colspan="5">= 300 baud</td> </tr> <tr> <td>OFF</td> <td>OFF</td> <td>ON</td> <td colspan="5">= 600 baud</td> </tr> <tr> <td>OFF</td> <td>ON</td> <td>OFF</td> <td colspan="5">= 1200 baud</td> </tr> <tr> <td>OFF</td> <td>ON</td> <td>ON</td> <td colspan="5">= 2400 baud</td> </tr> <tr> <td>ON</td> <td>OFF</td> <td>OFF</td> <td colspan="5">= 4800 baud</td> </tr> <tr> <td>ON</td> <td>OFF</td> <td>ON</td> <td colspan="5">= 9600 baud (factory setting)</td> </tr> <tr> <td>ON</td> <td>ON</td> <td>OFF</td> <td colspan="5">= 19200 baud</td> </tr> <tr> <td>ON</td> <td>ON</td> <td>ON</td> <td colspan="5">= 38400 baud</td> </tr> </table>								<b>3</b>	<b>4</b>	<b>5</b>	<b>Baud rate</b> <b>(all divisions should be set to the same baud rate)</b>					OFF	OFF	OFF	= 300 baud					OFF	OFF	ON	= 600 baud					OFF	ON	OFF	= 1200 baud					OFF	ON	ON	= 2400 baud					ON	OFF	OFF	= 4800 baud					ON	OFF	ON	= 9600 baud (factory setting)					ON	ON	OFF	= 19200 baud					ON	ON	ON	= 38400 baud				
	<b>3</b>	<b>4</b>	<b>5</b>	<b>Baud rate</b> <b>(all divisions should be set to the same baud rate)</b>																																																																												
	OFF	OFF	OFF	= 300 baud																																																																												
	OFF	OFF	ON	= 600 baud																																																																												
	OFF	ON	OFF	= 1200 baud																																																																												
	OFF	ON	ON	= 2400 baud																																																																												
	ON	OFF	OFF	= 4800 baud																																																																												
	ON	OFF	ON	= 9600 baud (factory setting)																																																																												
	ON	ON	OFF	= 19200 baud																																																																												
	ON	ON	ON	= 38400 baud																																																																												
	<table border="1"> <tr> <td><b>6</b></td> <td><b>7</b></td> <td colspan="6"><b>Data format</b> <b>(all divisions should be set to the same parity)</b></td> </tr> <tr> <td>OFF</td> <td>OFF</td> <td colspan="6">= 7E2 (7 bits, even parity, 2 stop bits)</td> </tr> <tr> <td>OFF</td> <td>ON</td> <td colspan="6">= 7O2 (7 bits, odd parity, 2 stop bits)</td> </tr> <tr> <td>ON</td> <td>OFF</td> <td colspan="6">= 8N1 (8 bits, no parity, 1stop bit) (factory setting)</td> </tr> <tr> <td>ON</td> <td>ON</td> <td colspan="6">= 8N1 (8 bits, no parity, 1stop bit)</td> </tr> </table>								<b>6</b>	<b>7</b>	<b>Data format</b> <b>(all divisions should be set to the same parity)</b>						OFF	OFF	= 7E2 (7 bits, even parity, 2 stop bits)						OFF	ON	= 7O2 (7 bits, odd parity, 2 stop bits)						ON	OFF	= 8N1 (8 bits, no parity, 1stop bit) (factory setting)						ON	ON	= 8N1 (8 bits, no parity, 1stop bit)																																					
	<b>6</b>	<b>7</b>	<b>Data format</b> <b>(all divisions should be set to the same parity)</b>																																																																													
	OFF	OFF	= 7E2 (7 bits, even parity, 2 stop bits)																																																																													
	OFF	ON	= 7O2 (7 bits, odd parity, 2 stop bits)																																																																													
	ON	OFF	= 8N1 (8 bits, no parity, 1stop bit) (factory setting)																																																																													
	ON	ON	= 8N1 (8 bits, no parity, 1stop bit)																																																																													
<table border="1"> <tr> <td><b>8</b></td> <td colspan="7"><b>Sign type</b> <b>(all divisions should be set to the same height)</b></td> </tr> <tr> <td>OFF</td> <td colspan="7">= 3.2-inch character height</td> </tr> <tr> <td>ON</td> <td colspan="7">= 1.4 or 2.1-inch character height</td> </tr> </table>								<b>8</b>	<b>Sign type</b> <b>(all divisions should be set to the same height)</b>							OFF	= 3.2-inch character height							ON	= 1.4 or 2.1-inch character height																																																							
<b>8</b>	<b>Sign type</b> <b>(all divisions should be set to the same height)</b>																																																																															
OFF	= 3.2-inch character height																																																																															
ON	= 1.4 or 2.1-inch character height																																																																															

### DIP switch example

The following example uses a 12 row x 80 character sign that is composed of:

- two sections (left, center, and right)
- six divisions
- three panels

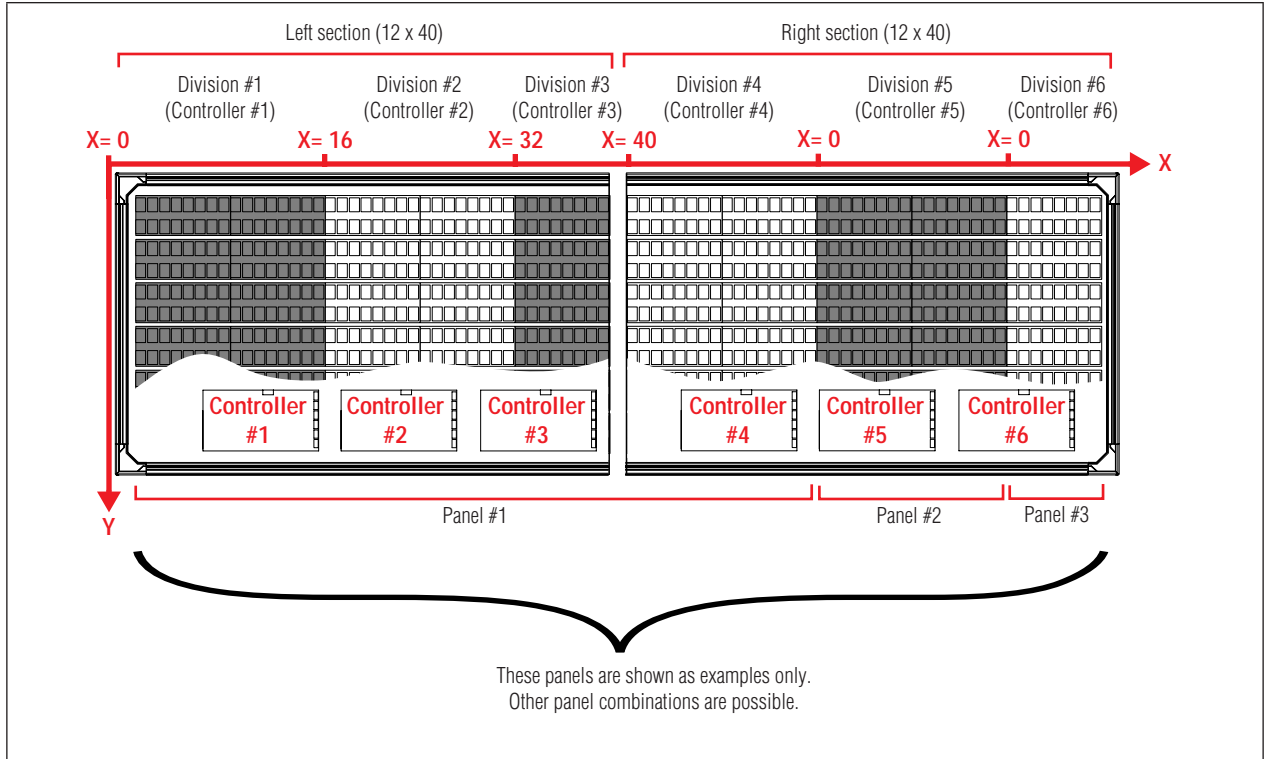

#### Controller board 1 DIP switch settings (0 = OFF, 1 = ON)

Use division's panel address	SW1								SW2								SW3								SW4								SW5								SW6																																															
	1	2	3	4	5	6	7	8	1	2	3	4	5	6	7	8	1	2	3	4	5	6	7	8	1	2	3	4	5	6	7	8	1	2	3	4	5	6	7	8	1	2	3	4	5	6	7	8																																								
	Division's panel address = 1	1	0	0	0	0	0	0	1	0	0	0	0	0	1	1	0	0	0	0	1	0	0	0	0	0	0	0	0	0	0	0	0	1	0	0	0	0	0	0	0	0	0	1	0	1	1	0	1																																							
Brightness area = 80									Division height = 12								Division width = 16								Normal operating mode								Division Y coordinate = 0								Master mode								Division X coordinate = 0								unused								Baud rate = 9600								Data format = 8N1								Sign type = 1.4 or 2.1-inch							

#### Controller board 2 DIP switch settings (0 = OFF, 1 = ON)

Use division's panel address	SW1								SW2								SW3								SW4								SW5								SW6																																															
	1	2	3	4	5	6	7	8	1	2	3	4	5	6	7	8	1	2	3	4	5	6	7	8	1	2	3	4	5	6	7	8	1	2	3	4	5	6	7	8	1	2	3	4	5	6	7	8																																								
	Division's panel address = 1	1	0	0	0	0	0	0	1	0	0	0	0	0	1	1	0	0	0	0	1	0	0	0	0	0	0	0	0	0	0	0	0	0	0	0	1	0	0	0	0	0	0	1	0	1	1	0	1																																							
Brightness area = 80									Division height = 12								Division width = 16								Normal operating mode								Division Y coordinate = 0								Slave mode								Division X coordinate = 16								unused								Baud rate = 9600								Data format = 8N1								Sign type = 1.4 or 2.1-inch							

Controller board 3 DIP switch settings (0 = OFF, 1 = ON)																																																							
SW1								SW2								SW3								SW4								SW5								SW6															
1	2	3	4	5	6	7	8	1	2	3	4	5	6	7	8	1	2	3	4	5	6	7	8	1	2	3	4	5	6	7	8	1	2	3	4	5	6	7	8	1	2	3	4	5	6	7	8								
1	0	0	0	0	0	0	1	0	0	0	0	0	1	1	0	0	0	0	0	1	0	0	0	0	0	0	0	0	0	0	0	0	0	1	0	0	0	0	0	0	0	1	0	1	1	0	1								
Use division's panel address Division's panel address = 1								Brightness area = 80								Division height = 12								Division width = 8								Normal operating mode Division Y coordinate = 0								Slave mode Division X coordinate = 32								unused Baud rate = 9600 Data format = 8N1 Sign type = 1.4 or 2.1-inch							

Controller board 4 DIP switch settings (0 = OFF, 1 = ON)																																																							
SW1								SW2								SW3								SW4								SW5								SW6															
1	2	3	4	5	6	7	8	1	2	3	4	5	6	7	8	1	2	3	4	5	6	7	8	1	2	3	4	5	6	7	8	1	2	3	4	5	6	7	8	1	2	3	4	5	6	7	8								
1	0	0	0	0	0	0	1	0	0	0	0	0	1	1	0	0	0	0	1	0	0	0	0	0	0	0	0	0	0	0	0	0	0	1	0	1	0	0	0	0	0	1	0	1	1	0	1								
Use division's panel address Division's panel address = 1								Brightness area = 80								Division height = 12								Division width = 16								Normal operating mode Division Y coordinate = 0								Slave mode Division X coordinate = 40								unused Baud rate = 9600 Data format = 8N1 Sign type = 1.4 or 2.1-inch							

Controller board 5 DIP switch settings (0 = OFF, 1 = ON)																																																							
SW1								SW2								SW3								SW4								SW5								SW6															
1	2	3	4	5	6	7	8	1	2	3	4	5	6	7	8	1	2	3	4	5	6	7	8	1	2	3	4	5	6	7	8	1	2	3	4	5	6	7	8	1	2	3	4	5	6	7	8								
1	0	0	0	0	0	1	0	0	0	0	0	0	1	1	0	0	0	0	1	0	0	0	0	0	0	0	0	0	0	0	0	0	0	0	0	0	0	0	0	0	0	1	0	1	1	0	1								
Use division's panel address Division's panel address = 2								Brightness area = 80								Division height = 12								Division width = 16								Normal operating mode Division Y coordinate = 0								Slave mode Division X coordinate = 0								unused Baud rate = 9600 Data format = 8N1 Sign type = 1.4 or 2.1-inch							

Controller board 6 DIP switch settings (0 = OFF, 1 = ON)																																																							
SW1								SW2								SW3								SW4								SW5								SW6															
1	2	3	4	5	6	7	8	1	2	3	4	5	6	7	8	1	2	3	4	5	6	7	8	1	2	3	4	5	6	7	8	1	2	3	4	5	6	7	8	1	2	3	4	5	6	7	8								
1	0	0	0	0	0	1	1	0	0	0	0	0	1	1	0	0	0	0	0	1	0	0	0	0	0	0	0	0	0	0	0	0	0	0	0	0	0	0	0	0	0	1	0	1	1	0	1								
Use division's panel address Division's panel address = 3								Brightness area = 80								Division height = 12								Division width = 8								Normal operating mode Division Y coordinate = 0								Slave mode Division X coordinate = 0								unused Baud rate = 9600 Data format = 8N1 Sign type = 1.4 or 2.1-inch							

**Jumper settings**

Each “jumper” is actually a pair of short pins which can be electrically connected with a small, rectangular box that fits over and connects the pins. The small box is often referred to as the “jumper”.

Controller board jumpers JP3, JP4, JP5, and JP6 are used to set RS485 termination. These jumpers are set at the factory and should not have to be changed. Setting these jumpers incorrectly could result in faulty communication. For example, a message may not appear on the sign or may appear incorrectly.

However, these controller board jumpers may need to be changed if a controller board is:

- moved
- replaced

**Determining controller board position**

To set controller board jumpers, find out if the board is in the “first”, “middle”, or “last” position:

- A controller board that is the first board connected to the RS485 input is in the first position.
- A controller board that is the farthest from the RS485 input is in the last position.
- All other controller boards are in the middle position.

Use the following illustration as a guide:

**Setting controller board jumpers**

Position	Jumper ("YES" = jumper in place)			
	JP3	JP4	JP5	JP6
First	—	—	YES	YES
Middle	—	—	—	—
Last	YES	YES	YES	YES

Jumpers are shown on JP5 and JP6 in "Figure 11: Controller board" on page 16.

## Appendix B: Opening a sign

---

1. Disconnect power from the sign. Note that signs may have multiple power entries.

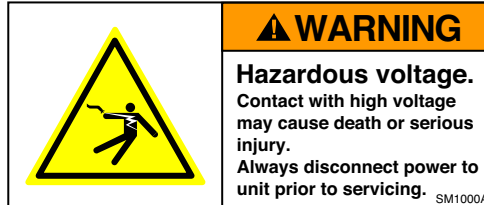

2. Use a Phillips screwdriver to remove all the screws that hold the screen retainer frame to the sign. Then remove the front screen (or screens) from the sign:

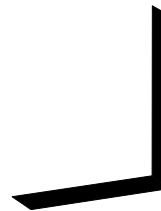
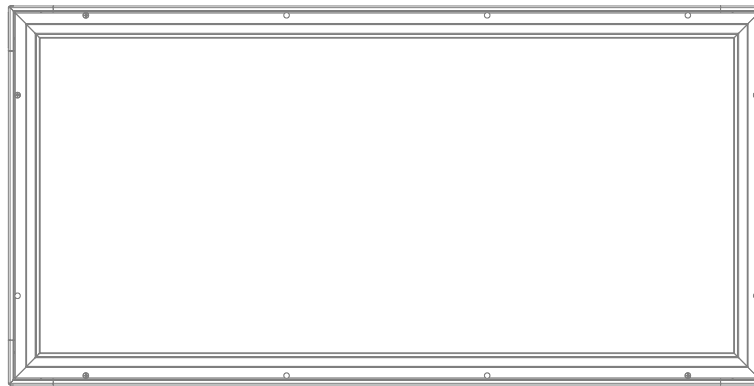

3. Remove the screw at the bottom of each vertical rail and lift up the LED display boards.

**NOTE:** Do NOT place your hands underneath the LED boards themselves as this could damage the boards.

4. Use the prop rod(s) to support the LED display boards:

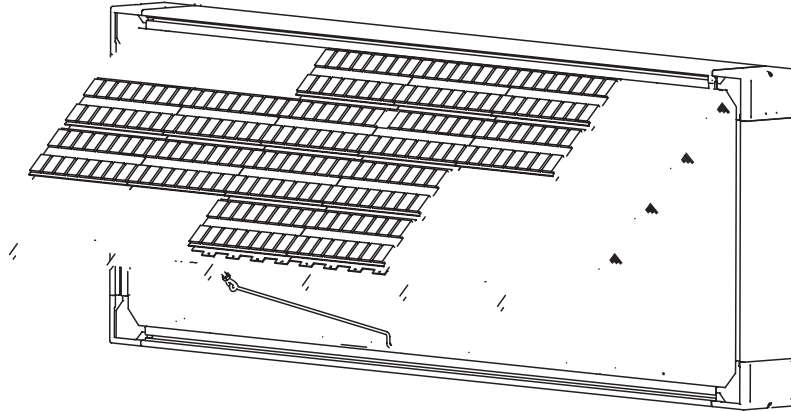

5. Turn each sign section's power switch to the OFF (0) position:



### Appendix C: Multi-section sign network wiring

1. Open the sign. See “Appendix B: Opening a sign” on page 23.
2. Connect RS485 wiring to all sign sections using the illustration below as a guide:

**NOTE:** RS485 termination (see “DIP switch example” on page 20) must also be set for each controller board. In the example below, controller board #1 is in the “first” position, controller boards #2 through #5 the “middle” position, and controller board #5 in the “last” position.

Shown below is a 1.4-inch character, 12-line x 80-character sign made up of a left section and a right section. Other sign sizes are similar.

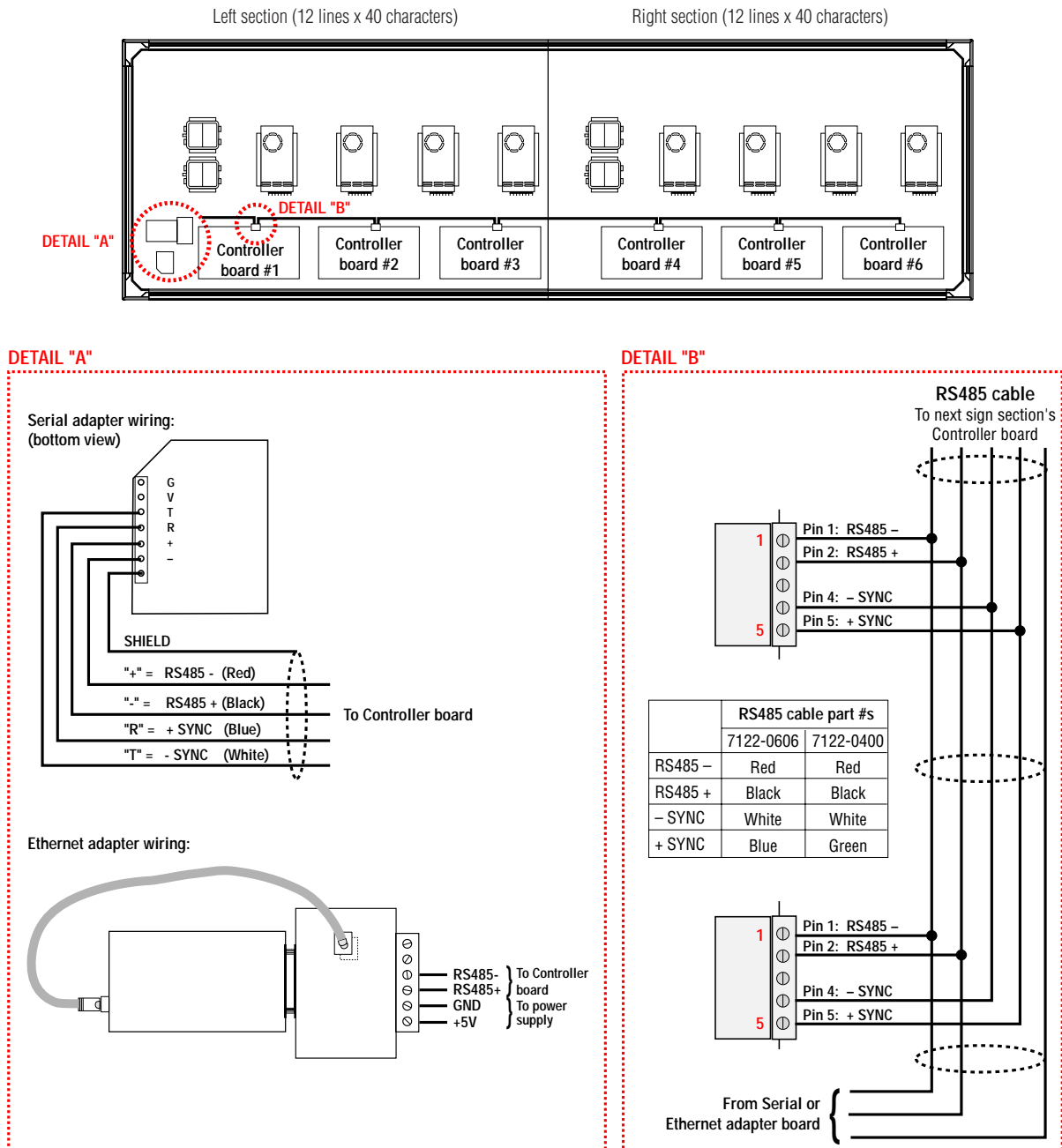

Figure 16: Multi-section sign network wiring

## Appendix D: Technical specifications

### 1.4-inch LED character height technical specifications

Super bright red LED model	Tricolor LED model	Characters per row	Rows	Controller boards	LED boards	Power supplies	Maximum average output current (AMP)	Maximum 100V RMS input current (AMP)	Maximum 200V RMS input current (AMP)
AVIT016006P02SBR	AVIT016006P02TRI	16	6	1	6	1	19.8	1.54	0.769
AVIT024006P02SBR	AVIT024006P02TRI	24	6	1	9	2	29.7	2.31	1.153
AVIT032006P02SBR	AVIT032006P02TRI	32	6	1	12	2	39.6	3.08	1.538
AVIT040006P02SBR	AVIT040006P02TRI	40	6	1	15	2	49.5	3.84	1.922
AVIT048006P02SBR	AVIT048006P02TRI	48	6	2	18	3	59.4	4.61	2.306
AVIT056006P02SBR	AVIT056006P02TRI	56	6	2	21	3	69.3	5.38	2.691
AVIT064006P02SBR	AVIT064006P02TRI	64	6	2	24	3	79.2	6.15	3.075
AVIT072006P02SBR	AVIT072006P02TRI	72	6	2	27	4	89.1	6.92	3.459
AVIT080006P02SBR	AVIT080006P02TRI	80	6	2	30	4	99	7.69	3.844
AVIT088006P02SBR	AVIT088006P02TRI	88	6	3	33	5	108.9	8.46	4.228
AVIT096006P02SBR	AVIT096006P02TRI	96	6	3	36	5	118.8	9.23	4.613
AVIT016008P02SBR	AVIT016008P02TRI	16	8	1	8	1	26.4	2.05	1.025
AVIT024008P02SBR	AVIT024008P02TRI	24	8	1	12	2	39.6	3.08	1.538
AVIT032008P02SBR	AVIT032008P02TRI	32	8	1	16	2	52.8	4.10	2.050
AVIT040008P02SBR	AVIT040008P02TRI	40	8	2	20	3	66	5.13	2.563
AVIT048008P02SBR	AVIT048008P02TRI	48	8	2	24	3	79.2	6.15	3.075
AVIT056008P02SBR	AVIT056008P02TRI	56	8	2	28	4	92.4	7.18	3.588
AVIT064008P02SBR	AVIT064008P02TRI	64	8	2	32	4	105.6	8.20	4.100
AVIT072008P02SBR	AVIT072008P02TRI	72	8	3	36	5	118.8	9.23	4.613
AVIT080008P02SBR	AVIT080008P02TRI	80	8	3	40	5	132	10.25	5.125
AVIT088008P02SBR	AVIT088008P02TRI	88	8	3	44	6	145.2	11.28	5.638
AVIT096008P02SBR	AVIT096008P02TRI	96	8	3	48	6	158.4	12.00	6.150
AVIT016010P02SBR	AVIT016010P02TRI	16	10	1	10	2	33	2.56	1.281
AVIT024010P02SBR	AVIT024010P02TRI	24	10	1	15	2	49.5	3.84	1.922
AVIT032010P02SBR	AVIT032010P02TRI	32	10	2	20	3	66	5.13	2.563
AVIT040010P02SBR	AVIT040010P02TRI	40	10	2	25	4	82.5	6.41	3.203
AVIT048010P02SBR	AVIT048010P02TRI	48	10	2	30	4	99	7.69	3.844
AVIT056010P02SBR	AVIT056010P02TRI	56	10	3	35	5	115.5	8.97	4.484
AVIT064010P02SBR	AVIT064010P02TRI	64	10	3	40	5	132	10.25	5.125
AVIT072010P02SBR	AVIT072010P02TRI	72	10	3	45	6	148.5	11.53	5.766
AVIT016012P02SBR	AVIT016012P02TRI	16	12	1	12	2	39.6	3.08	1.538
AVIT024012P02SBR	AVIT024012P02TRI	24	12	2	18	3	59.4	4.61	2.306
AVIT032012P02SBR	AVIT032012P02TRI	32	12	2	24	3	79.2	6.15	3.075
AVIT040012P02SBR	AVIT040012P02TRI	40	12	3	30	4	99	7.69	3.844
AVIT048012P02SBR	AVIT048012P02TRI	48	12	3	36	5	118.8	9.23	4.613
AVIT056012P02SBR	AVIT056012P02TRI	56	12	4	42	6	138.6	10.76	5.381
AVIT064012P02SBR	AVIT064012P02TRI	64	12	4	48	6	158.4	12.00	6.150
AVIT016014P02SBR	AVIT016014P02TRI	16	14	1	14	2	46.2	3.59	1.794
AVIT024014P02SBR	AVIT024014P02TRI	24	14	2	21	3	69.3	5.38	2.691
AVIT032014P02SBR	AVIT032014P02TRI	32	14	2	28	4	92.4	7.18	3.588
AVIT040014P02SBR	AVIT040014P02TRI	40	14	3	35	5	115.5	8.97	4.484
AVIT048014P02SBR	AVIT048014P02TRI	48	14	3	42	6	138.6	10.76	5.381
AVIT016016P02SBR	AVIT016016P02TRI	16	16	1	16	2	52.8	4.10	2.050
AVIT024016P02SBR	AVIT024016P02TRI	24	16	2	24	3	79.2	6.15	3.075
AVIT032016P02SBR	AVIT032016P02TRI	32	16	2	32	4	105.6	8.20	4.100
AVIT040016P02SBR	AVIT040016P02TRI	40	16	3	40	5	132	10.25	5.125
AVIT048016P02SBR	AVIT048016P02TRI	48	16	3	48	6	158.4	12.00	6.150

Super bright red LED model	Tricolor LED model	Characters per row	Rows	Controller boards	LED boards	Power supplies	Maximum average output current (AMP)	Maximum 100V RMS input current (AMP)	Maximum 200V RMS input current (AMP)
AVIT018018P02SBR	AVIT018018P02TRI	18	18	2	20.25	3	66.825	5.19	2.595
AVIT024018P02SBR	AVIT024018P02TRI	24	18	3	27	4	89.1	6.92	3.459
AVIT032018P02SBR	AVIT032018P02TRI	32	18	4	36	5	118.8	9.23	4.613
AVIT040018P02SBR	AVIT040018P02TRI	40	18	5	45	6	148.5	11.53	5.766
AVIT018020P02SBR	AVIT018020P02TRI	18	20	2	22.5	3	74.25	5.77	2.883
AVIT024020P02SBR	AVIT024020P02TRI	24	20	3	30	4	99	7.69	3.844
AVIT032020P02SBR	AVIT032020P02TRI	32	20	4	40	5	132	10.25	5.125
AVIT018022P02SBR	AVIT018022P02TRI	18	22	2	24.75	4	81.675	6.34	3.171
AVIT024022P02SBR	AVIT024022P02TRI	24	22	3	33	5	108.9	8.46	4.228
AVIT032022P02SBR	AVIT032022P02TRI	32	22	4	44	6	145.2	11.28	5.638
AVIT018024P02SBR	AVIT018024P02TRI	18	24	2	27	4	89.1	6.92	3.459
AVIT024024P02SBR	AVIT024024P02TRI	24	24	3	36	5	118.8	9.23	4.613
AVIT032024P02SBR	AVIT032024P02TRI	32	24	4	48	6	158.4	12.30	6.150
AVIT018026P02SBR	AVIT018026P02TRI	18	26	2	29.25	4	96.525	7.50	3.748
AVIT024026P02SBR	AVIT024026P02TRI	24	26	3	39	5	128.7	9.99	4.997
AVIT018028P02SBR	AVIT018028P02TRI	18	28	2	31.5	4	103.95	8.07	4.036
AVIT024028P02SBR	AVIT024028P02TRI	24	28	3	42	6	138.6	10.76	5.381
AVIT018030P02SBR	AVIT018030P02TRI	18	30	3	33.75	5	111.375	8.65	4.324
AVIT024030P02SBR	AVIT024030P02TRI	24	30	3	45	6	148.5	11.53	5.766
AVIT024030P02SBR	AVIT024030P02TRI	24	32	3	48	6	?	12.00	6.15

### 2.1-inch LED character height technical specifications

Super bright red LED model	Tricolor LED model	Characters per row	Rows	Controller boards	LED boards	Power supplies	Maximum average output current (AMP)	Maximum 100V RMS input current (AMP)	Maximum 200V RMS input current (AMP)
AVIT024004P03SBR	AVIT024004P03TRI	24	4	1	6	1	19.8	1.54	0.77
AVIT032004P03SBR	AVIT032004P03TRI	32	4	1	8	1	26.4	2.05	1.02
AVIT040004P03SBR	AVIT040004P03TRI	40	4	1	10	2	33	2.57	1.28
AVIT048004P03SBR	AVIT048004P03TRI	48	4	1	12	2	39.6	3.08	1.54
AVIT056004P03SBR	AVIT056004P03TRI	56	4	1	14	2	46.2	3.59	1.79
AVIT064004P03SBR	AVIT064004P03TRI	64	4	1	16	2	52.8	4.11	2.05
AVIT016006P03SBR	AVIT016006P03TRI	16	6	1	6	1	19.8	1.54	0.769
AVIT024006P03SBR	AVIT024006P03TRI	24	6	1	9	2	29.7	2.31	1.153
AVIT032006P03SBR	AVIT032006P03TRI	32	6	1	12	2	39.6	3.08	1.538
AVIT040006P03SBR	AVIT040006P03TRI	40	6	1	15	2	49.5	3.84	1.922
AVIT048006P03SBR	AVIT048006P03TRI	48	6	2	18	3	59.4	4.61	2.306
AVIT056006P03SBR	AVIT056006P03TRI	56	6	2	21	3	69.3	5.38	2.691
AVIT064006P03SBR	AVIT064006P03TRI	64	6	2	24	3	79.2	6.15	3.075
AVIT016008P03SBR	AVIT016008P03TRI	16	8	1	8	1	26.4	2.05	1.025
AVIT024008P03SBR	AVIT024008P03TRI	24	8	1	12	2	39.6	3.08	1.538
AVIT032008P03SBR	AVIT032008P03TRI	32	8	1	16	2	52.8	4.10	2.050
AVIT040008P03SBR	AVIT040008P03TRI	40	8	2	20	3	66	5.13	2.563
AVIT048008P03SBR	AVIT048008P03TRI	48	8	2	24	3	79.2	6.15	3.075
AVIT056008P03SBR	AVIT056008P03TRI	56	8	2	28	4	92.4	7.18	3.588
AVIT064008P03SBR	AVIT064008P03TRI	64	8	2	32	4	105.6	8.20	4.100
AVIT016010P03SBR	AVIT016010P03TRI	16	10	1	10	2	33	2.56	1.281
AVIT024010P03SBR	AVIT024010P03TRI	24	10	1	15	2	49.5	3.84	1.922
AVIT032010P03SBR	AVIT032010P03TRI	32	10	2	20	3	66	5.13	2.563

AVIT040010P03SBR	AVIT040010P03TRI	40	10	2	25	4	82.5	6.41	3.203
AVIT048010P03SBR	AVIT048010P03TRI	48	10	2	30	4	99	7.69	3.844
AVIT056010P03SBR	AVIT056010P03TRI	56	10	3	35	5	115.5	8.97	4.484
AVIT064010P03SBR	AVIT064010P03TRI	64	10	3	40	5	132	10.25	5.125
AVIT016012P03SBR	AVIT016012P03TRI	16	12	1	12	2	39.6	3.08	1.538
AVIT024012P03SBR	AVIT024012P03TRI	24	12	2	18	3	59.4	4.61	2.306
AVIT032012P03SBR	AVIT032012P03TRI	32	12	2	24	3	79.2	6.15	3.075
AVIT040012P03SBR	AVIT040012P03TRI	40	12	3	30	4	99	7.69	3.844
AVIT048012P03SBR	AVIT048012P03TRI	48	12	3	36	5	118.8	9.23	4.613
AVIT056012P03SBR	AVIT056012P03TRI	56	12	4	42	6	138.6	10.76	5.381
AVIT064012P03SBR	AVIT064012P03TRI	64	12	4	48	6	158.4	12.00	6.150
AVIT016014P03SBR	AVIT016014P03TRI	16	14	1	14	2	46.2	3.59	1.794
AVIT024014P03SBR	AVIT024014P03TRI	24	14	2	21	3	69.3	5.38	2.691
AVIT032014P03SBR	AVIT032014P03TRI	32	14	2	28	4	92.4	7.18	3.588
AVIT040014P03SBR	AVIT040014P03TRI	40	14	3	35	5	115.5	8.97	4.484
AVIT048014P03SBR	AVIT048014P03TRI	48	14	3	42	6	138.6	10.76	5.381
AVIT016016P03SBR	AVIT016016P03TRI	16	16	1	16	2	52.8	4.10	2.050
AVIT024016P03SBR	AVIT024016P03TRI	24	16	2	24	3	79.2	6.15	3.075
AVIT032016P03SBR	AVIT032016P03TRI	32	16	2	32	4	105.6	8.20	4.100
AVIT040016P03SBR	AVIT040016P03TRI	40	16	3	40	5	132	10.25	5.125
AVIT048016P03SBR	AVIT048016P03TRI	48	16	3	48	6	158.4	12.00	6.150
AVIT018018P03SBR	AVIT018018P03TRI	16	18	2	18	3	59.4	4.61	2.306
AVIT024018P03SBR	AVIT024018P03TRI	24	18	3	27	4	89.1	6.92	3.459
AVIT032018P03SBR	AVIT032018P03TRI	32	18	4	36	5	118.8	9.23	4.613
AVIT040018P03SBR	AVIT040018P03TRI	40	18	5	45	6	148.5	11.53	5.766
AVIT018020P03SBR	AVIT018020P03TRI	16	20	2	20	3	66	5.13	2.563
AVIT024020P03SBR	AVIT024020P03TRI	24	20	3	30	4	99	7.69	3.844
AVIT032020P03SBR	AVIT032020P03TRI	32	20	4	40	5	132	10.25	5.125