

AlphaEclipse™ Excite™ 35mm Series Outdoor LED Display



excite™ Series

The AlphaEclipse Excite 35 is designed to provide the ultimate outdoor advertising experience. The 35mm pitch produces a dominant, outdoor full color LED digital sign for higher speed roads around town, for highly elevated locations, or for highway installations that cannot be ignored.

Digital Design - All DVI digital connectivity, and reliability – throughout our entire design. PureColor™ LED processing wows your targeted viewing audience with dynamic color and dramatic visibility. Standard Embedded PC design enables powerful control; fast downloads of huge files, and industry standard Ethernet connectivity.

Maintenance Free - All weather Protector™ case design eliminates vents, filters and environmental contaminants. No more corrosion issues or concerns associated with rain, dust, and salt fog. To provide another level of protection, sensitive internal electronics are conformal coated.

- Video board or marquee message center – Two different standard product offerings
- Flexible – Many modular sizes from 2' x 5' to 14' x 48' billboard dimensions
- Powerful – Visible from 100' to over 2500', medium resolution fits any main street or highway need
- Efficient – Energy Smart LED technology that is affordable, reliable and energy efficient
- Profitable – No other out-of-home medium provides a faster ROI through increased sales & profits

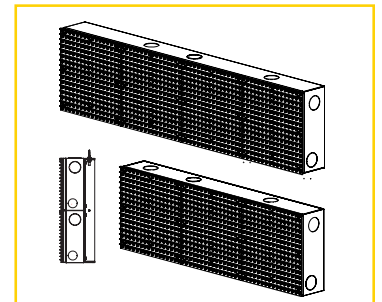

Standard Features

- All digital design with industry standard DVI architecture
- Embedded PC with Ethernet connectivity
- Alphamation graphic library – hundreds of animations
- Video display processing 60fps
- Message marquee 20fps display processing
- Ooh!Media™ software
- Peace-of-Mind 5-year factory parts warranty
- Wired, wireless Ethernet, DSL or cable modem
- Digital PureColor™ processing - 16.7 million colors

AlphaEclipse™ Excite™ 35mm Series Specifications*

| Rows | Columns | Height | Width | Weight | 10" Characters Per Line** | Character Height Choices** | Number of Shippable Sections | Number of Power Entries | Total AC Current Req. (Amps) | Power Entry A (Amps) | Power Entry B (Amps) |
|------|---------|--------|--------|--------|---------------------------|----------------------------|------------------------------|-------------------------|------------------------------|----------------------|----------------------|
| 16 | 96 | 1'10" | 11'1" | 204 | 16/2 | 7" - 22" | 1 | 1 | 11.1 | 11.1 | - |
| 16 | 112 | 1'10" | 12'11" | 238 | 18/2 | | 1 | 1 | 13.0 | 13.0 | - |
| 24 | 96 | 2'9" | 11'1" | 306 | 16/3 | 7" - 33" | 1 | 1 | 16.7 | 16.7 | - |
| 24 | 112 | 2'9" | 12'11" | 357 | 18/3 | | 1 | 1 | 19.4 | 19.4 | - |
| 32 | 96 | 3'8" | 11'1" | 408 | 16/4 | 7" - 44" | 1 | 1 | 22.2 | 22.2 | - |
| 32 | 112 | 3'8" | 12'11" | 476 | 18/4 | | 1 | 1 | 25.9 | 25.9 | - |
| 40 | 96 | 4'8" | 11'1" | 510 | 16/5 | 7" - 55" | 1 | 1 | 27.8 | 27.8 | - |
| 40 | 112 | 4'8" | 12'11" | 595 | 18/5 | | 1 | 1 | 32.4 | 32.4 | - |
| 48 | 96 | 5'7" | 11'1" | 612 | 16/6 | 7" - 66" | 1 | 1 | 33.3 | 33.3 | - |
| 48 | 112 | 5'7" | 12'11" | 714 | 18/6 | | 1 | 1 | 38.9 | 38.9 | - |
| 48 | 128 | 5'7" | 14'9" | 816 | 21/6 | | 1 | 1 | 44.4 | 44.4 | - |
| 64 | 128 | 7'5" | 14'9" | 1080 | 21/8 | 7" - 88" | 2 | 2 | 59.2 | 44.4 | 14.8 |
| 64 | 144 | 7'5" | 16'7" | 1224 | 24/8 | | 4 | 2 | 66.6 | 50.0 | 16.7 |
| 64 | 160 | 7'5" | 18'5" | 1360 | 26/8 | | 4 | 2 | 74.0 | 55.5 | 18.5 |
| 80 | 144 | 9'3" | 16'7" | 1530 | 24/10 | 7" - 110" | 4 | 2 | 83.3 | 50.0 | 33.3 |
| 80 | 160 | 9'3" | 18'5" | 1700 | 26/10 | | 4 | 2 | 92.5 | 55.5 | 37.0 |
| 96 | 160 | 11'1" | 18'5" | 2040 | 26/12 | 7" - 132" | 6 | 2 | 111.0 | 55.5 | 55.5 |
| 96 | 176 | 11'1" | 20'3" | 2244 | 29/12 | | 6 | 2 | 122.1 | 61.1 | 61.1 |
| 128 | 416 | 14'9" | 47'10" | 7022 | 69/15 | 7" - 177" | 12 | 3 | 290.3 | 144.3 | 146.0 |

Adaptive® manufactures two series types; **Excite marquee message centers** with 20 fps performance, and **Excite Video boards** offering high speed video performance at 60 fps. All series offer digital PureColor™ processing, high brightness, and wide viewing angles to produce a dynamic, visual impact like no other digital signage product available today.

| | |
|---|--|
| LED Pixel: | 35mm/1.38 inch pitch 2Red/2Green/1Blue LED |
| LED Color: | PureColor™ 8-bit, 16.7 million colors |
| Digital Display Matrix Size: | Min. 16 x 64 / Max. 128 x 416 (for marquee center or video board) |
| Digital Display Case Dimensions: | Min. 22.5" x 66.5" / Max. 15' x 48" - 9.75" deep (including 3" steel mounting angle) |
| Viewability & Intensity: | 140° horizontal/60° vertical, 6500 nits minimum |
| Viewing Distance: | Min. 100ft., Max. to +2500ft. (1" of character height=40ft. of viewing distance) |
| Power/Module: | 78 watts maximum per module (8 x 16 display driver) |
| Controller: | Embedded PC, DVI link to the sign monitor |
| Connectivity to Controller: | Wired or wireless Ethernet, and DSL or cable modem (third party requirement) |
| Service Access: | Front access door opens to enable access to all internal components. Display drivers (8 x 16) are removable without opening the front access door |
| Case Material: | UL50 type 3R, IP44 aluminum cabinet |
| Mounting: | Steel mounting angle for welding, bolting to third party superstructure |
| Size & Weight per Module: | 10.04" x 22.04", ~17lbs. per 8 x 16 display driver |
| Dimming Feature: | 10 automatic levels |

| | |
|-------------------------------|---|
| Video Frame Rate: | Message marquee version: 20fps Excite Video version: 60fps |
| Special Features: | <ul style="list-style-type: none"> -Industry standard 1Gigabyte compact flash memory for message storage -External temperature probe (optional) -Marquee and Video models have DVI monitor capability -Protector™ case – enclosure design eliminates external contamination by rain, salt fog or dust and reflects solar radiation. -Conformal coated electronics seals out condensation/moisture penetration -Automatic thermal protection for all electronics -One thermostatically controlled fan per module for internal air mixing. |
| Filtering Maintenance: | Not required, no external vents |
| Operating Temperature: | -40° to 122° F / -40° to 50° C |
| Limited Warranty: | Five-year limited factory depot warranty. Third party supplied devices such as modems, wireless devices, carry a warranty respective of the supplier. See Adaptive Terms & Conditions for complete warranty details. |
| Agency Approvals: | FCC Part 15, Class A, ANSI/UL 60950-1 CAN/CSA C22.2 No. 60950-1-03 C-ETL-US listing mark and CE Marking |

NOTE: Many more sizes are available, up to 15' x 48' (128 rows x 416 columns).

Approximate dimensions, power and weight – call your Adaptive dealer for architectural/engineering drawings before beginning your project design.
*Due to continuing product innovations, all specifications are subject to change without notice. ** Based upon Adaptive standard character fonts.